

BBAH Plexiglass inspection pipes

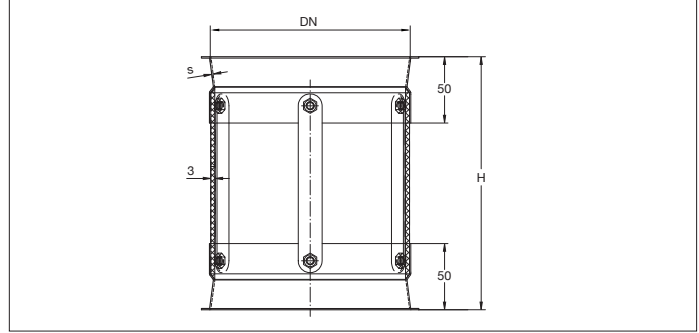

BBAH Plexiglass inspection pipes

Full welded plexiglass inspection pipe to see the material flowing through the ducting. Small external support legs reinforce the structure.

The plexiglass is glued against the metal body to ensure airtightness.

These inspection pipes are suitable for the transport of waste materials such as dust and chips but also for the transport of grains and such.

Material

1.00 and 1.50 mm stainless steel AISI 304, chronital blasted.

Type

Rolled sheets with 6 mm edges for lock rings.

Options

- FDA and EU compliant food-grade quality
- equipotential equalization
- other types of edges or connections

Ø d mm	Code	H mm	s mm	Weight kg
100	BBAH000002	200	1.00	0.62
120	BBAH000003	200	1.00	0.72
150	BBAH000004	200	1.00	0.76
175	BBAH000005	200	1.50	0.92
200	BBAH000006	250	1.50	1.40
250	BBAH000007	250	1.50	1.20
300	BBAH000008	250	1.50	2.20