

**XCUTTER - Turbo-cutter**

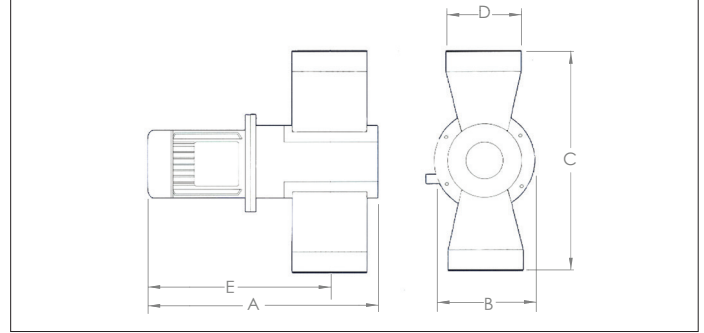

**XCUTTER - Turbo-cutter**

The turbo-cutter removes edges, cut-offs and trimmings with an integrated cutting- and suction technique which cuts the down to small pieces which can then be conveyed to the refuse container, compactor, combustion or to further preparation.

The turbo-cutter is developed especially for industries, which require a quick, effective and economic shredding of trimmings from one or more sources and works under vacuum, which means that dust and other contaminated particles are extracted together with the rest of the material.

The size of the cut off material depends on the amount of knives, the knife rotation speed and the speed of the airflow within the ducting.

**Applications :**

- Paper: Paper- and computer industry
- Cardboard: Packing industry
- Plastic foil: Plastic industry
- Packing: Packing industry
- Label, laminate: Printing works
- Fibers: Synthetic industry
- Textile: Textile industry

**Material**

Die-cast steel powder coated.  
Hardened steel cutting knives.

**Type**

2 mm inlet cones bolted to housing

**Options**

- Different sizes in- and outlets (Ø100 to Ø200)
- Set of knives

**Other information**

- 0,55 to 1,1 kW B5 flanged motor
- Speed : on request
- Elec. Supply : 3x380v, 50 Hz
- Starter : Manual/direct
- Current : 1,75 A
- Fuse rating : 10 amp
- Transmission : Direct through overload coupling
- Pressure loss : about 80mm wg at 1500 m<sup>3</sup> air/h

**Dimensions :**

Model	# of Knives	Motor Power (kW)	A (mm)	B (mm)	C (mm)	ØD <sup>1)</sup> (mm)	E (mm)	Weight (kg)
XCUTTER055-6P	3	0.55	483	200	450	100 to 200	350	32
XCUTTER075-4P	3	0.75	483	200	450	100 to 200	350	32
XCUTTER110-2P	3	1.1	483	200	450	100 to 200	350	32

<sup>1)</sup> Specify when ordering

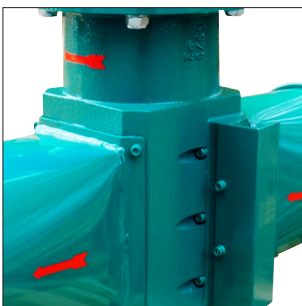

**Sturdy construction**  
Construction is made to last and is weather resistant.



**Gearing**  
High grade metal gear and NSK bearings.

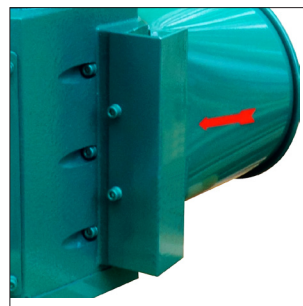

**Easy adjustments**  
Fine tuning of cutting is easily done by exterior adjustment.



**Knives**  
High grade steel knives insure long lasting working.