

AAED Sweep-ups

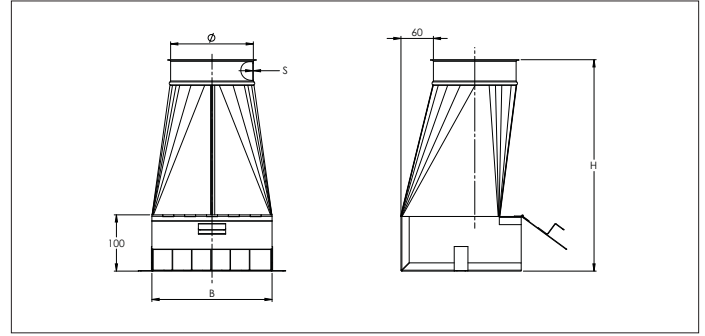

AAED Sweep-ups

Sweep-ups for the suction of dust, wood particles and debris in a workshop for use in overpressure, under-pressure and pressureless systems.

Supplied with an access door and grill.

Material

Sendzimir galvanized DX51 DZ 275 MAC.

Type

Rolled and cut sheets, spot-welded together, with 6 mm edges for lock rings.

Options

- without grill or lid
- other diameters
- other sheet thicknesses depending on diameter and length
- other types of edges or connections

| Ø | Code | B mm | H mm | s mm | Weight kg |
|-----|------------|---------|---------|---------|--------------|
| 80 | AAED000001 | 220 | 390 | 0.88 | 2.60 |
| 100 | AAED000002 | 220 | 390 | 0.88 | 2.70 |
| 120 | AAED000003 | 220 | 390 | 0.88 | 2.76 |
| 125 | AAED000013 | 220 | 390 | 0.88 | 2.77 |
| 140 | AAED000004 | 220 | 390 | 0.88 | 2.81 |
| 150 | AAED000005 | 220 | 390 | 0.88 | 2.84 |
| 160 | AAED000006 | 220 | 390 | 0.88 | 2.87 |
| 180 | AAED000007 | 220 | 390 | 0.88 | 2.90 |
| 200 | AAED000008 | 220 | 390 | 0.88 | 3.90 |
| 225 | AAED000009 | 300 | 390 | 0.88 | 3.95 |
| 250 | AAED000010 | 300 | 390 | 0.88 | 4.00 |
| 275 | AAED000011 | 300 | 390 | 0.88 | 4.05 |
| 280 | AAED000012 | 300 | 390 | 0.88 | 4.06 |