

BAHJ Pneumatic branch diverters 45° with seal

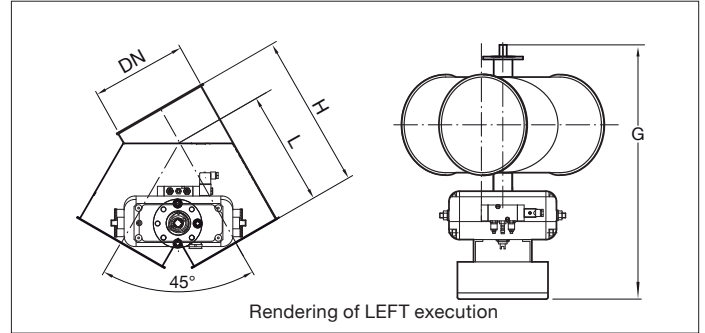

BAHJ Pneumatic branch diverters 45° with seal
Full welded round pneumatic branch diverter with interior collar and silicone seal for bulk transport to silos, containers and such.

The change in direction of the material is operated by a pneumatic rotating actuator connected to a bistable 5/2 solenoid valve, 24V DC with limit switches. The inner plate is mounted on two ball bearings for smooth running.

These diverters are designed to be used for falling material and light pneumatic transport (for example wood chips, polystyrene, etc.) in vertical ductin in a right or left execution (to specify when ordering).

Material
2.00 mm powder coated black steel in RAL 7032.
Electrostatically conductive and food-safe powder coating thickness of 30 to 60 µm.
Temperature resistance up to +80°C.
Silicone seal.

Type
Rolled and welded plates with 6 mm edges for lock rings.

- Options**
- FDA and EU compliant food-grade quality
 - with other seal material
 - stainless steel execution
 - equipotential equalization or ATEX
 - 230V AC solenoid valve
 - other colors
 - 3 mm sheet thicknesses, depending on material and diameter
 - other types of edges or connections

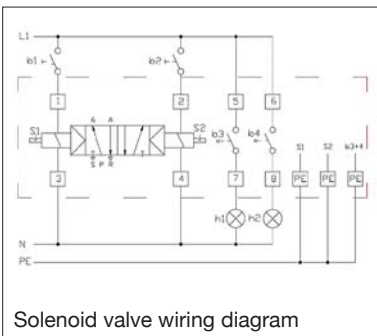

! Max. air pressure in solenoid valve : 8 Bar.

Diverter with seal

Ø d mm	Code		G mm	H mm	L mm	Thickness mm	Weight kg
	Left	Right					
100	BAHJ000125	BAHJ000141	455	226	185	2.00	12.00
120	BAHJ000126	BAHJ000142	475	373	228	2.00	13.00
150	BAHJ000127	BAHJ000143	505	321	270	2.00	16.00
175	BAHJ000128	BAHJ000144	530	367	310	2.00	19.00
200	BAHJ000129	BAHJ000145	575	412	350	2.00	22.00
250	BAHJ000130	BAHJ000146	625	501	418	2.00	28.00
300	BAHJ000131	BAHJ000147	685	590	497	2.00	34.00
350	BAHJ000132	BAHJ000148	735	705	547	2.00	40.00
400	BAHJ000133	BAHJ000149	785	850	667	2.00	52.00