

CZEA Injection pipes

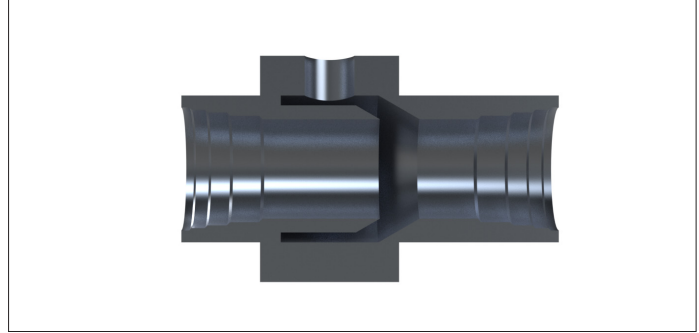

CZEA Injection pipes

The Venturi injection pipes make it possible to create a centralized cleaning system on an existing medium pressure industrial ducting system.

It is also a reliable and economic transport method for powders, granulates and other objects.

The suction power of the transport is adjusted according to the inlet speed. With its compact size, it is installed as close as possible to the workspace for an optimal efficiency.

These pipes are available in three standard models from 25 to 50 mm internal.

The electrovalves are fed by inertia and only consume energy when in use. The outlet pressure allows for the use of a filter, cyclone or other methods of waste filtration.

Characteristics

- In-line venturi designed for the pneumatic transport and centralized cleaning
- Completely static, starts and stops immediately
- To be installed in line in centralized cleaning ducting
- from 0 to about 10 kg/min of transported material
- Different types of executions depending on the use
- No moving parts, no seals
- Passage diameter from 25 to 50 mm

Technical information

Fluid : Compressed air
 Optimal pressure : 5,5 bars
 Pressure range : 0 to 10 bars
 Consumption : See table
 Temperature range : -50° to +250 °C (AISI version)

Functioning principle

Compressed air is injected in the exterior ring which contains 6 conduits directed towards the inside of the central tube. At the outlets of these conduits, the air reaches supersonic speed. The exterior air is then sucked into the central tube and turns making an helicoidal movement.

This cyclonic movement creates a strong airflow which can carry materials into the tube and then into the rest of the ducting along tens of meters.

Applications

- Enables the user to connect a high pressure system to a mid-pressure installation
- Transport of powders, granulates and objects
- To increase the efficiency of a centralized system
- Evacuate debris and waste (wood, leather, string, cardboard, fiber, ink, paper & chips)

Safety advice

Always earth the pipe to avoid electrostatic build-up.

Material

Anodized aluminum

Accessories :

- see frames below

Options

- Stainless steel
- Imperative 5µ filtration



Connector 1/2" - 3/8"



Regulator 1/2"



Coupling 3/8" Male or Female



Male stud 1/2"

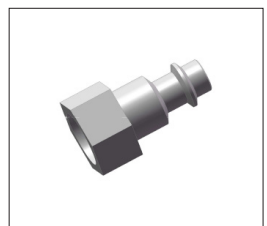

Female stud 1/2"

CZEA Injection pipes

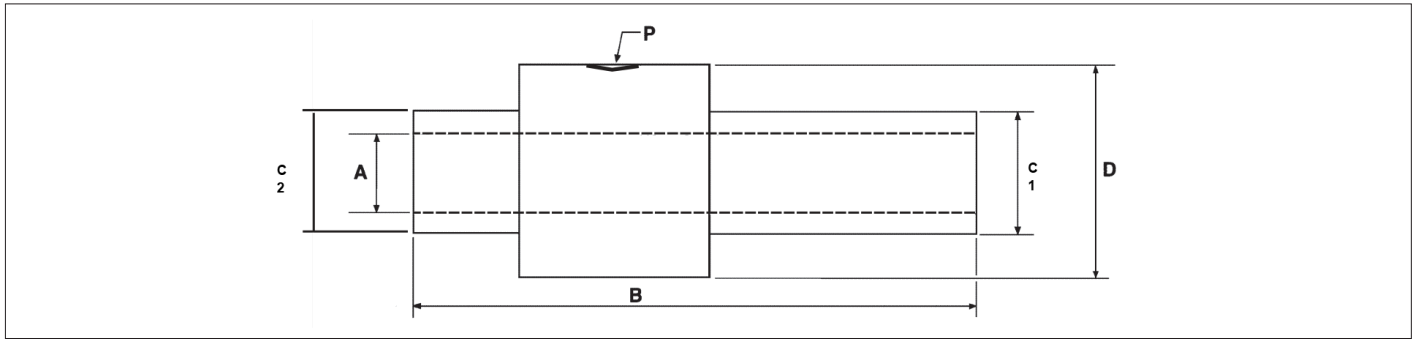

Dimensions :

Type	Code	d int. A Ø mm	B mm	Ø C1 mm	Ø C2 mm	Ø D mm	Connection
38-38	CZEA000001	25	190	37.7	37	57	G 3/8
50-50	CZEA000002	38	190	50.3	49.7	70	G 3/8
63-63	CZEA000003	50	190	63.1	62.4	82	G 3/8

Consumption :

Code	Max. pressure in mbar < Patm. at 5.5 bar	Air Volume in N/m ³ h at 5.5 bar	Consumption in NI/min at 5.5 bar	Air speed in m/s at 5.5 bar
CZEA000001	195	162	1350	88
CZEA000002	85	342	1350	83
CZEA000003	50	510	1350	70

Installation :

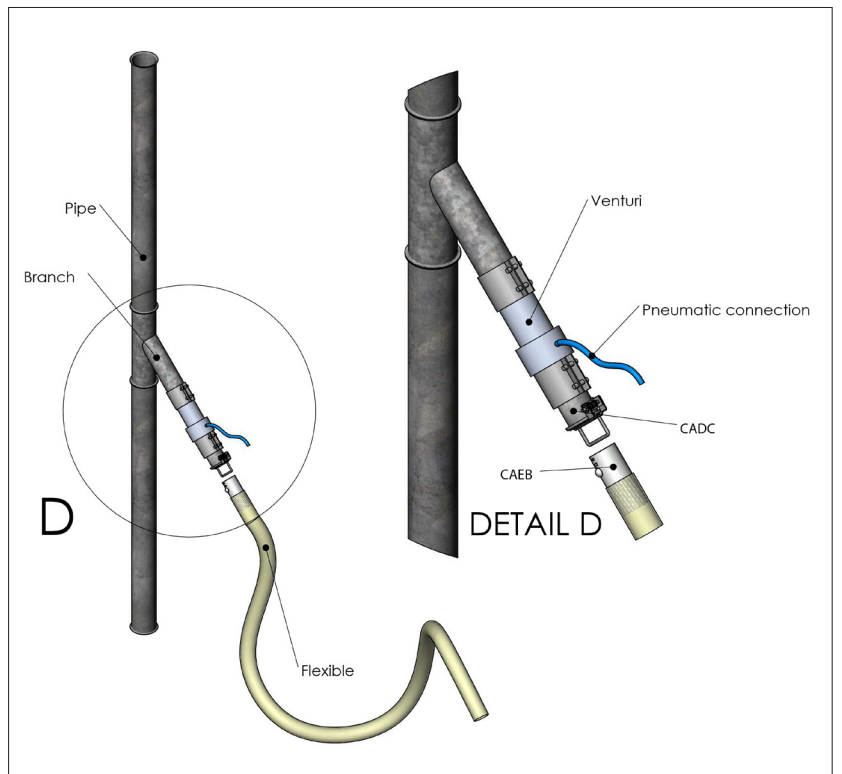
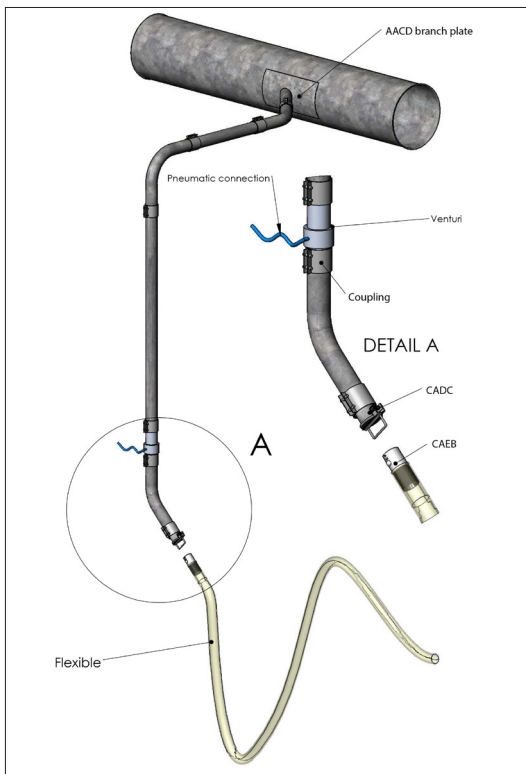

> Simple and economical connection to an industrial ducting system

> Simple and economical connection to a centralized cleaning system