

BAGF Bagging spouts and BZZM straps

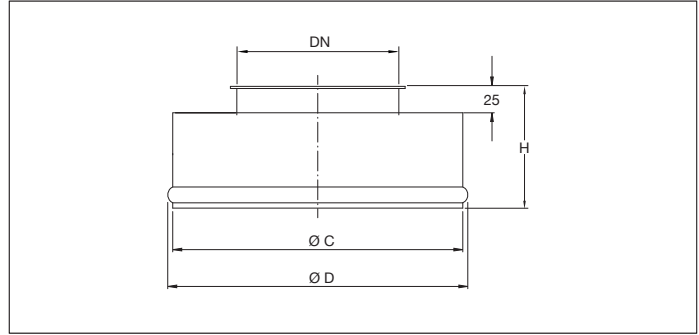

BAGF Bagging spouts and BZZM straps

Pipe piece especially designed to be connected under a cyclone, a silo, or a filter to attach a Big-Bag or sack to recuperate falling material.

The sack side is foreseen with a boom to ensure the tight fit with the leather strap.

The leather bagging strap has two fixing lanyards to attach to the bagging spout and a quick-lock mechanism to attach the sack or bag.

Material

1.50 mm powder coated black steel in RAL 7032.
Electrostatically conductive and food-safe powder coating thickness of 30 to 60 µm.
Temperature resistance up to +80°C.

Type

Rolled sheets with 6 mm edges for lock rings.

Options

- FDA and EU compliant food-grade quality
- hot-dipped galvanized or stainless steel execution
- equipotential equalization
- other colors
- other diameters
- other types of edges or connections

Bagging spouts

Ø d mm	Code	A mm	B mm	C mm	s mm	Weight kg
100	BAGF000002	275	295	115	1.50	1.49
120	BAGF000003	275	295	115	1.50	1.77
150	BAGF000004	275	295	115	1.50	1.80
175	BAGF000005	275	295	115	1.50	1.90
200	BAGF000006	275	295	115	1.50	2.00
250	BAGF000007	275	295	115	1.50	2.10
300	BAGF000008	300	320	115	1.50	2.20

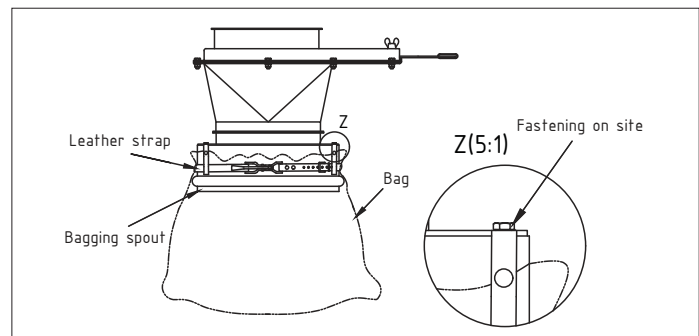
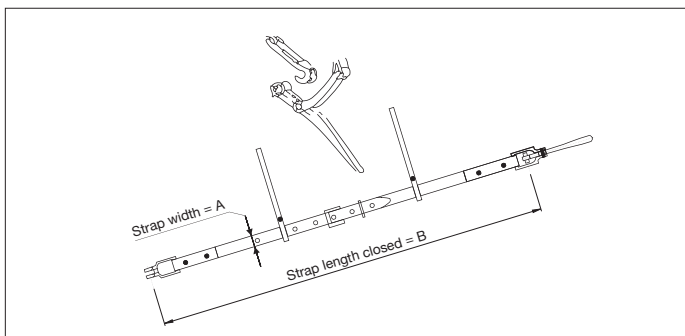

Leather bagging straps

Ø d mm	Code	A mm	B mm	Weight kg
100-315	BZZM000001	30	1100	0.42
350-630	BZZM000002	30	2040	0.49