



Formula Air

Supporting your performance



Cyclone FA

Maintenance Manual

Contents

| | |
|--|----|
| 1. PRODUCT DESCRIPTION | 2 |
| 1.1. How it works | 3 |
| 1.2. Accessories..... | 4 |
| 1.2.1. Supporting legs | 4 |
| 1.2.2. Dustbin | 4 |
| 1.2.3. Expansion chamber | 5 |
| 1.3. Overall dimensions..... | 6 |
| 1.4. Technical datasheet | 8 |
| 2. INTALLATION | 10 |
| 2.1. Cyclone installation..... | 10 |
| 2.2. Installation for a cyclone with legs | 11 |
| 2.3. Installation of the dustbin..... | 13 |
| 2.4. Removing the dustbin | 15 |
| 2.5. Installation of the expansion chamber | 16 |
| 3. MAINTENANCE & TROUBLESHOOTING..... | 18 |
| 3.1. Removing the dustbin transition | 18 |
| 3.2. Replacing the leg support | 18 |
| 3.3. Replacing a cyclone's part..... | 19 |
| 4. DISMANTLING & RECYCLING..... | 20 |
| 5. SPARE PARTS..... | 21 |

Cyclones FA. Maintenance Manual

1. PRODUCT DESCRIPTION

The cyclone FA is a high efficiency separator which guarantees an efficient separation of the fine as well as the bigger particles. It can be used for several industrial applications, such as heavy molding, grinding, planing, cabinet workshops, dust transfer systems or material separation.

It is an economical solution to a wide range of dust collection problems.

Manufactured in 2.0 mm or 3.0 mm sheet metal, powder coated RAL 5010 with a rustproof protection; it is easily mounted in or outdoors.

Legs, dustbin and expansion chamber are optional and are available as separate parts.

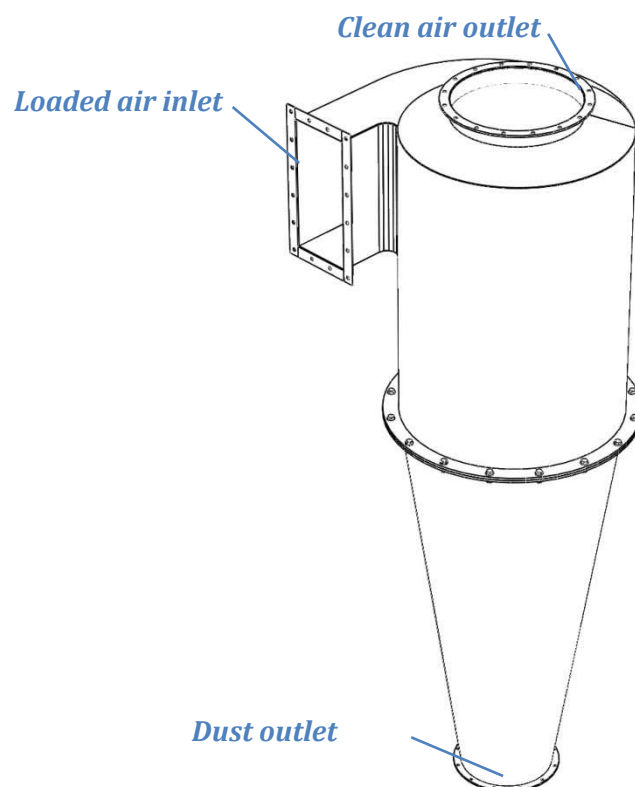

1.1. How it works

- During normal operation, dust laden air enters the FA cyclone unit through the loaded air inlet.
- The air and the material are diverted into a spiral motion around the inside perimeter. The centrifugal force applied by the sidewall allows the heavier material to fall out the dust outlet into the dust bin, or through a rotary valve.
- Clean air is carried through the inner cylinder and discharges into the atmosphere or secondary filters.

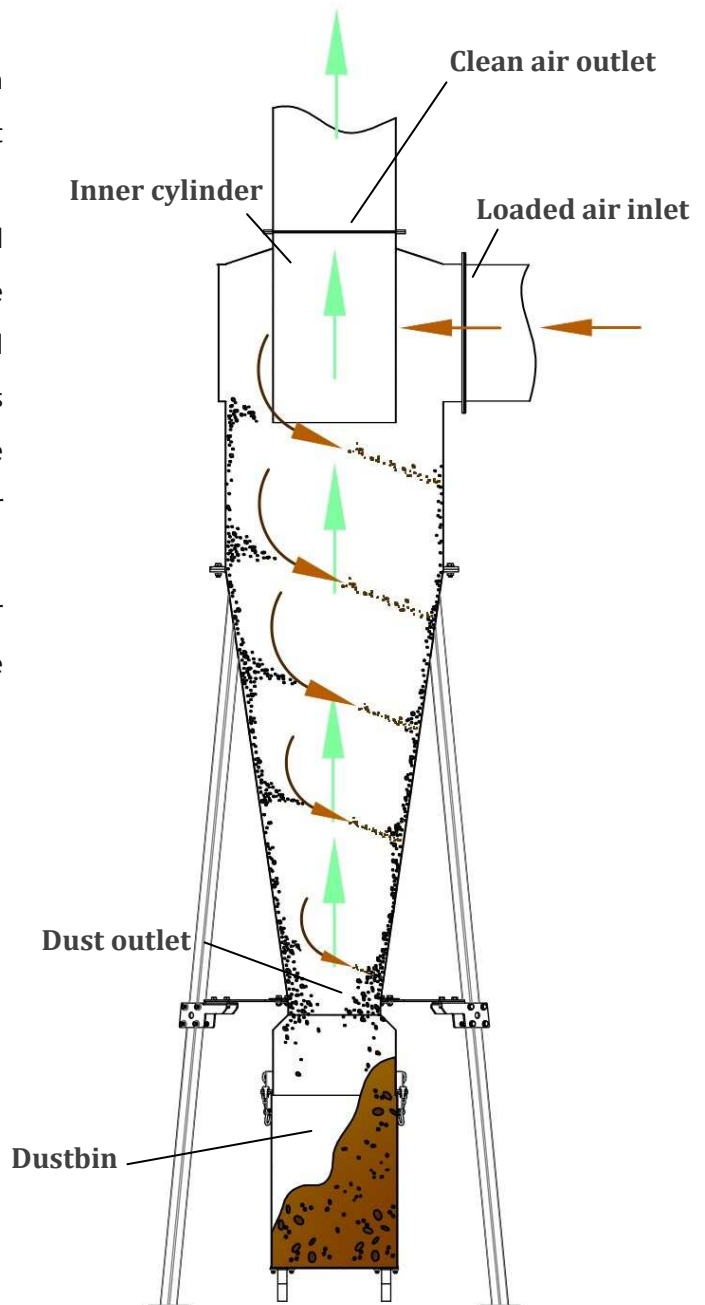

1.2. Accessories

1.2.1. Supporting legs

Square profiled legs, welded to 5mm or 8mm sheet metal holders. Powder coated RAL 5010.

* For overall dimensions, please see attached tables in **Chapter 1.3**.

** For technical data, please see attached tables in **Chapter 1.4**.

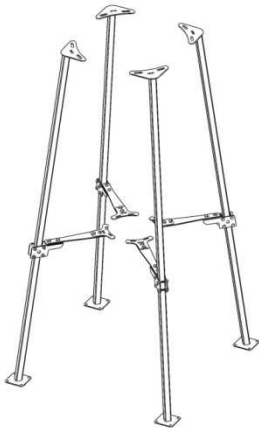

Supporting legs for FA cyclone

1.2.2. Dustbin

The dustbin collects the dust from the cyclone that is subtracted from the air and can be easily removed by opening the locks. After that, the dustbin can be moved by rolling it out on its integrated wheels. The dustbin is made of 2 mm ST37 sheet metal, powder coated in RAL 5010. The connector which connects the bin with the cyclone can be rigid or flexible.

* For overall dimensions, please see attached tables in **Chapter 1.3**.

** For technical data, please see attached tables in **Chapter 1.4**.

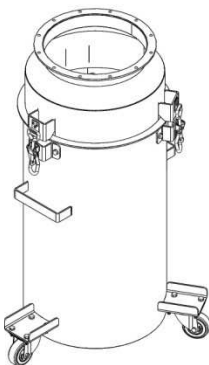

Dustbin with rigid connection

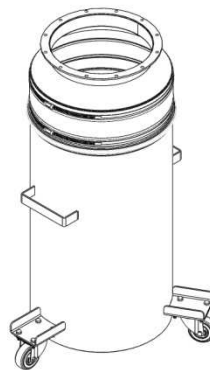

Dustbin with flexible connection

1.2.3. Expansion chamber

The expansion chamber allows to optimize the FA cyclone's efficiency and gives a better air/ dust separation. The expansion chamber is made of ST37 sheet metal, powder coated RAL5010.

* For overall dimensions, please see attached tables in **Chapter 1.3**.

** For technical data, please see attached tables in **Chapter 1.4**.

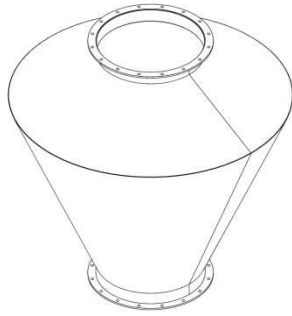

Expansion chamber

1.3. Overall dimensions

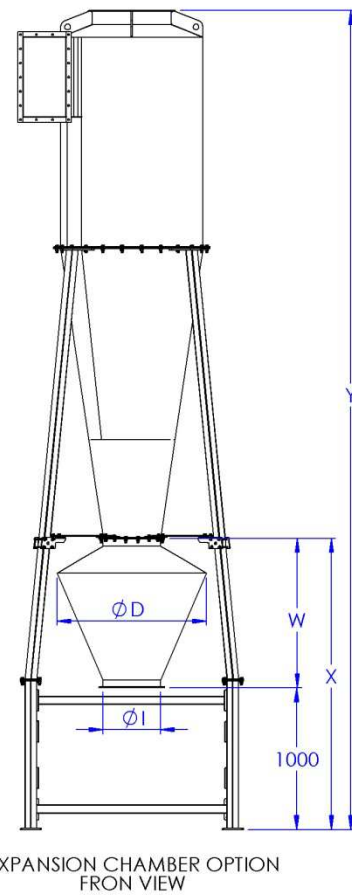
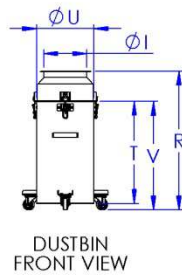
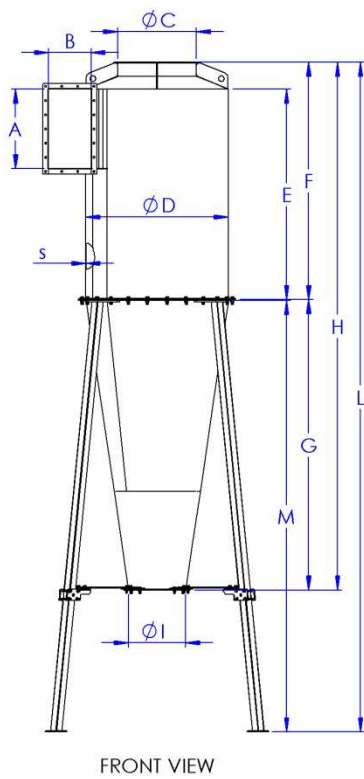
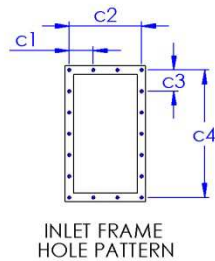
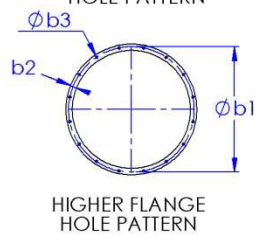
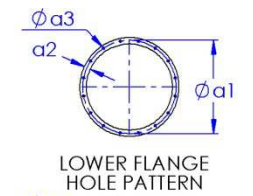
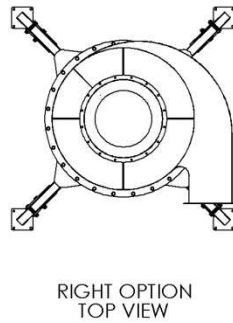
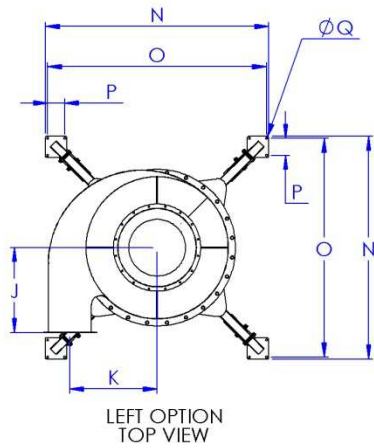

— Drawing Lines
— Dimensions

Cyclone

| Type | A mm | B mm | C mm | D mm | E mm | F mm | G mm | H mm | I mm | J mm | K mm | s mm |
|--------|---------|---------|---------|---------|---------|---------|---------|---------|---------|---------|---------|---------|
| FA-020 | 230 | 100 | ∅ 225 | ∅ 399 | 570 | 645 | 820 | 1465 | ∅ 160 | 240 | 234 | 2 |
| FA-035 | 285 | 125 | ∅ 250 | ∅ 499 | 710 | 770 | 1020 | 1790 | ∅ 200 | 300 | 290 | 2 |
| FA-050 | 350 | 160 | ∅ 250 | ∅ 499 | 710 | 770 | 1020 | 1790 | ∅ 200 | 300 | 308 | 2 |
| FA-065 | 445 | 200 | ∅ 400 | ∅ 709 | 998 | 1104 | 1414 | 2518 | ∅ 300 | 420 | 419 | 2 |
| FA-100 | 560 | 300 | ∅ 550 | ∅ 1000 | 1490 | 1675 | 2050 | 3725 | ∅ 400 | 600 | 615 | 2 |
| FA-130 | 750 | 400 | ∅ 698 | ∅ 1248 | 2000 | 2269 | 2820 | 5089 | ∅ 448 | 700 | 782 | 3 |
| FA-160 | 1100 | 500 | ∅ 798 | ∅ 1598 | 2000 | 2270 | 3150 | 5420 | ∅ 548 | 900 | 1050 | 3 |
| FA-180 | 1500 | 500 | ∅ 998 | ∅ 1798 | 2500 | 2800 | 3450 | 6250 | ∅ 628 | 950 | 1150 | 3 |

Legs, dustbin, expansion chamber

| Type | L mm | M mm | N mm | O mm | P mm | Q mm | R mm | T mm | U mm | V mm | W mm | X mm | Y mm |
|--------|---------|---------|---------|---------|---------|---------|---------|---------|---------|---------|---------|---------|---------|
| FA-020 | 2465 | 1816 | 670 | 840 | 100 | ∅ 14 | 980 | 720 | ∅ 401 | 765 | 454 | 1454 | 2919 |
| FA-035 | 2790 | 2012 | 981 | 951 | 100 | ∅ 14 | 980 | 720 | ∅ 401 | 765 | 554 | 1554 | 3344 |
| FA-050 | 2790 | 2012 | 981 | 951 | 100 | ∅ 14 | 980 | 720 | ∅ 401 | 765 | 554 | 1554 | 3344 |
| FA-065 | 3518 | 2414 | 1214 | 1184 | 100 | ∅ 14 | 980 | 720 | ∅ 401 | 765 | 764 | 1764 | 4282 |
| FA-100 | 4725 | 3042 | 1573 | 1543 | 120 | ∅ 14 | 980 | 720 | ∅ 401 | 765 | 1054 | 2054 | 5779 |
| FA-130 | 6089 | 3810 | 1955 | 1915 | 140 | ∅ 14 | 980 | 720 | ∅ 640 | 765 | 1304 | 2304 | 7393 |
| FA-160 | 6420 | 4140 | 2258 | 2218 | 140 | ∅ 14 | 980 | 720 | ∅ 640 | 765 | 1654 | 2654 | 8074 |
| FA-180 | 7250 | 4440 | 2501 | 2461 | 170 | ∅ 14 | 980 | 720 | ∅ 640 | 765 | 1854 | 2854 | 9104 |

Flanges

| Type | a1 mm | a2 mm | a3 mm | b1 mm | b2 mm | b3 mm | c1 mm | c2 mm | c3 mm | c4 mm | c5 mm |
|--------|----------|----------|------------|----------|----------|------------|----------|---------------|----------|----------------|----------|
| FA-020 | ∅ 215 | 25 | ∅ 9 (x8) | ∅ 280 | 25 | ∅ 9 (x12) | 70 | 140 (2x 70) | 90 | 270 (3x 90) | ∅ 13 |
| FA-035 | ∅ 255 | 25 | ∅ 9 (x12) | ∅ 305 | 25 | ∅ 9 (x12) | 82.5 | 165 (2x 82.5) | 108 | 325 (3x 108) | ∅ 13 |
| FA-050 | ∅ 255 | 25 | ∅ 9 (x12) | ∅ 305 | 25 | ∅ 9 (x12) | 100 | 200 (2x 100) | 97.5 | 390 (4x 97.5) | ∅ 13 |
| FA-065 | ∅ 336 | 25 | ∅ 9 (x12) | ∅ 439 | 30 | ∅ 11 (x16) | 80 | 240 (3x 80) | 97 | 485 (5x 97) | ∅ 13 |
| FA-100 | ∅ 465 | 30 | ∅ 11 (x16) | ∅ 615 | 30 | ∅ 11 (x16) | 113 | 340 (3x 113) | 100 | 600 (6x 100) | ∅ 13 |
| FA-130 | ∅ 515 | 30 | ∅ 11 (x16) | ∅ 785 | 40 | ∅ 11 (x24) | 110 | 440 (4x 110) | 99 | 790 (8x 99) | ∅ 13 |
| FA-160 | ∅ 615 | 30 | ∅ 11 (x16) | ∅ 885 | 40 | ∅ 11 (x24) | 108 | 540 (5x 108) | 104 | 1140 (11x 104) | ∅ 13 |
| FA-180 | ∅ 695 | 30 | ∅ 11 (x24) | ∅ 1085 | 40 | ∅ 11 (x24) | 108 | 540 (5x 108) | 103 | 1540 (15x 103) | ∅ 13 |

1.4. Technical datasheet

Cyclone FA

| Type | Total volume m ³ | Total mass kg | Higher cone mass kg | Lower cone mass kg |
|--------|--------------------------------|------------------|---------------------------|--------------------------|
| FA-020 | 0.13 | 40 | 25 | 15 |
| FA-035 | 0.25 | 57 | 35 | 23 |
| FA-050 | 0.25 | 58 | 36 | 23 |
| FA-065 | 0.7 | 113 | 70 | 43 |
| FA-100 | 2.08 | 226 | 143 | 83 |
| FA-130 | 4.3 | 538 | 339 | 199 |
| FA-160 | 7.3 | 754 | 475 | 278 |
| FA-180 | 10.95 | 1025 | 682 | 342 |

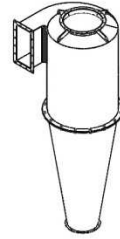

Cyclone FA with legs

| Type | Total volume m ³ | Total mass kg | Legs mass kg |
|--------|--------------------------------|------------------|-----------------|
| FA-020 | 0.13 | 78 | 37 |
| FA-035 | 0.25 | 99 | 41 |
| FA-050 | 0.25 | 100 | 41 |
| FA-065 | 0.7 | 162 | 49 |
| FA-100 | 2.08 | 326 | 100 |
| FA-130 | 4.3 | 692 | 154 |
| FA-160 | 7.3 | 922 | 168 |
| FA-180 | 10.95 | 1301 | 276 |

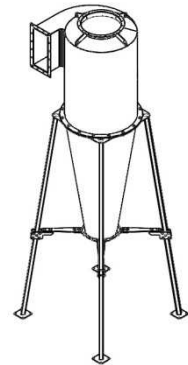

Cyclone FA with legs and dustbin

| Type | Total mass kg | Dustbin mass (with rigid connection) kg | Dustbin mass (with flexible connection) kg | Dustbin volume m ³ |
|--------|------------------|--|---|-------------------------------------|
| FA-020 | 111 | 29 | 27 | 0.1 |
| FA-035 | 132 | 29 | 27 | 0.1 |
| FA-050 | 133 | 29 | 27 | 0.1 |
| FA-065 | 195 | 29 | 27 | 0.1 |
| FA-100 | 360 | 29 | 27 | 0.1 |
| FA-130 | 747 | 52 | 50 | 0.2 |
| FA-160 | 977 | 52 | 50 | 0.2 |
| FA-180 | 1356 | 52 | 50 | 0.2 |

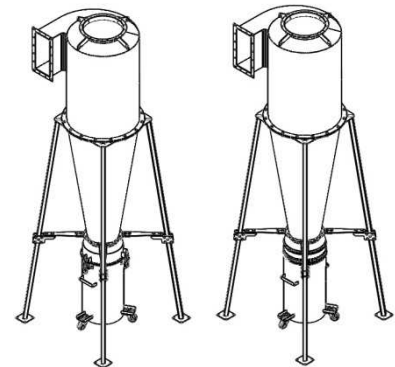

Cyclone FA with legs and expansion chamber

| Type | Total mass kg | Expansion chamber mass kg | Expansion chamber volume m ³ | Extra legs mass kg |
|--------|------------------|---------------------------------|---|--------------------------|
| FA-020 | 101 | 8 | 0.02 | 15 |
| FA-035 | 130 | 12 | 0.05 | 19 |
| FA-050 | 131 | 12 | 0.05 | 19 |
| FA-065 | 215 | 24 | 0.15 | 30 |
| FA-100 | 449 | 46 | 0.4 | 75 |
| FA-130 | 948 | 101 | 0.75 | 149 |
| FA-160 | 1281 | 164 | 1.54 | 190 |
| FA-180 | 1788 | 206 | 2.22 | 266 |



Pressure loss in FA cyclones

Diagram stating the pressure loss in FA cyclones at a given air volume.

2. INTALLATION

The installation of the cyclone has to be performed by qualified personnel only. For heavy parts use the right equipment and do not work alone.

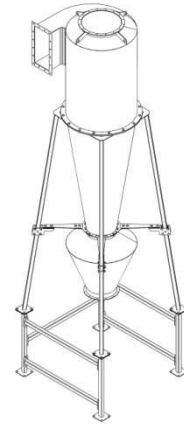
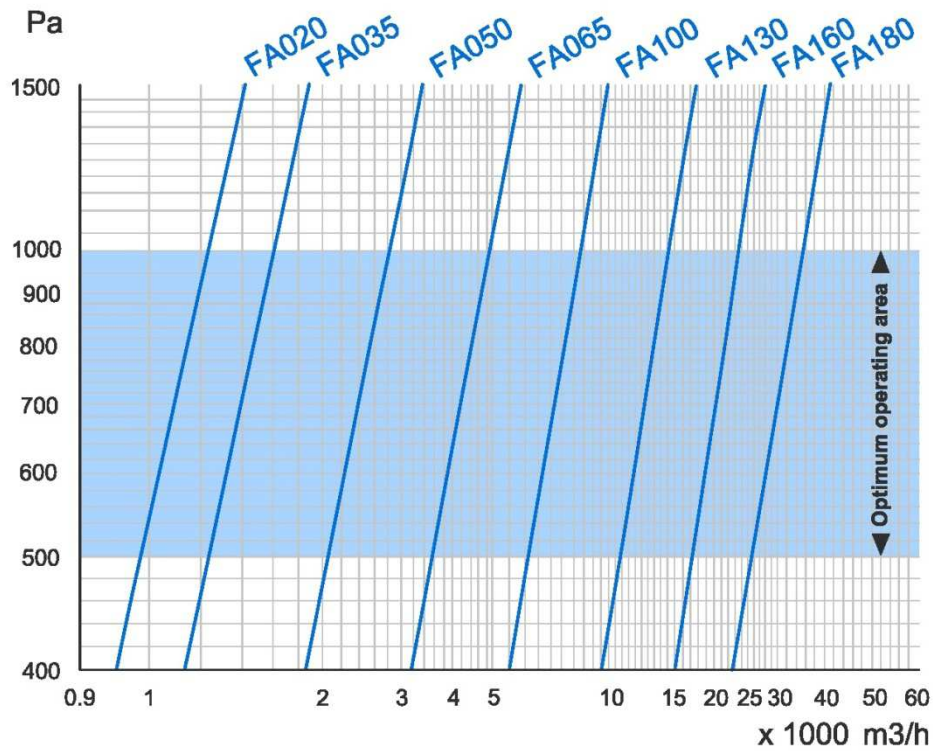
2.1. Cyclone installation

Step 1: Transport the cyclone to the desiderate place with the help of the lifting eyes.

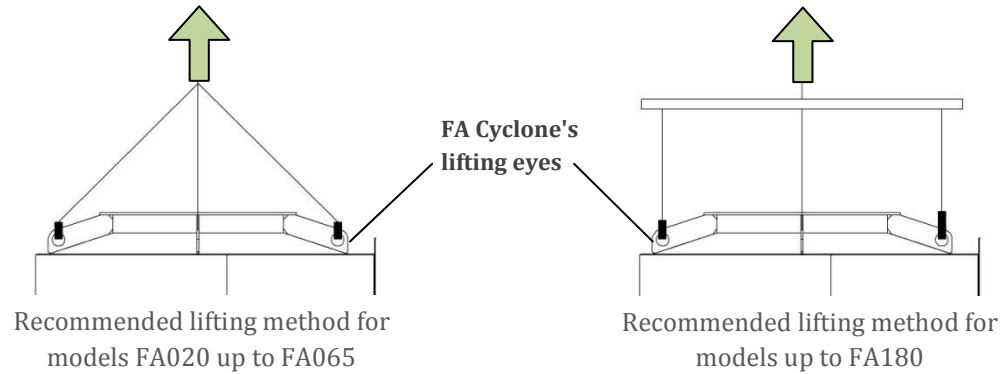

Step 2: Use sealing tape on the cyclones rectangular inlet duct and connect it to the duct with the correct fasteners.

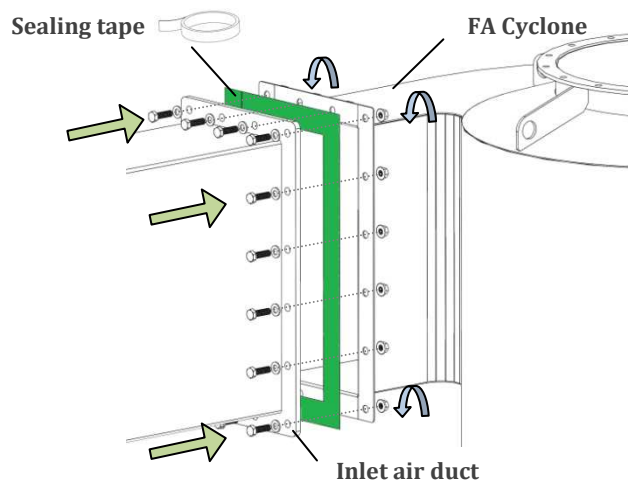

Step 3: Use sealing tape on the cyclones higher flange and connect it to the duct with the correct fasteners.

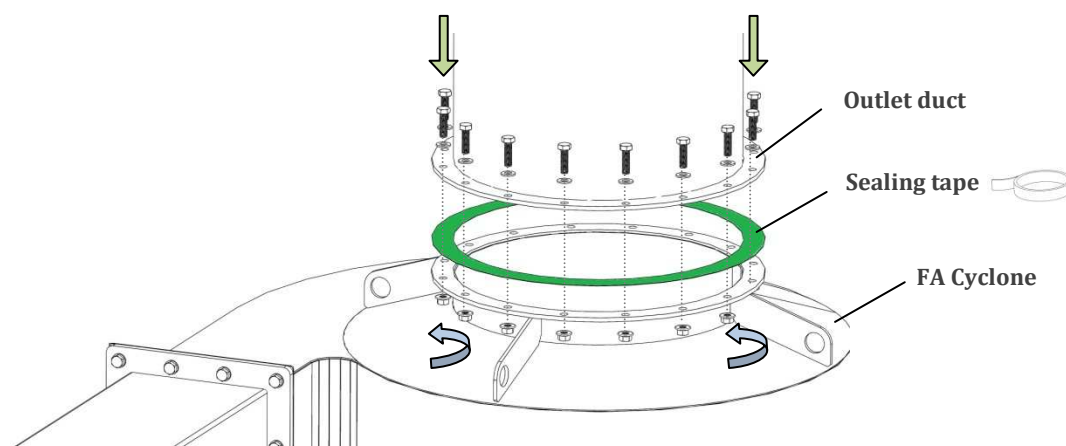

2.2. Installation for a cyclone with legs

Step 1: Please follow the installation steps in *Chapter 2.1.* for cyclone installation.

Step 2: Unscrew the bolts where legs are being positioned and position the leg to the bottom part of the cyclone's hopper flange.

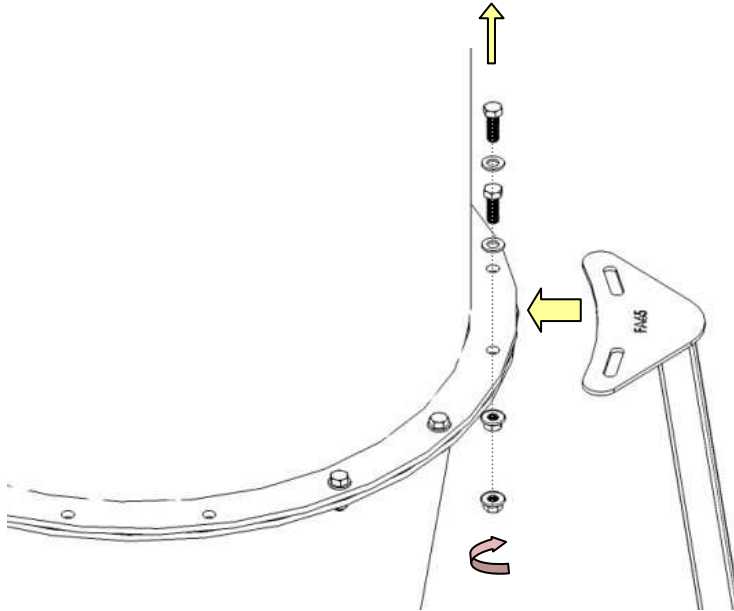

***CAUTION!** Make sure each leg is in the right position.

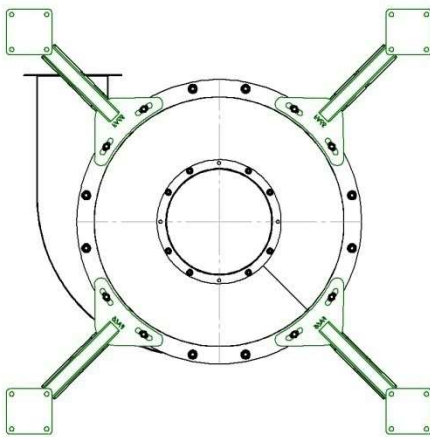

LEG SUPPORT POSITIONING FOR
FA CYCLONES LEFT SIDE

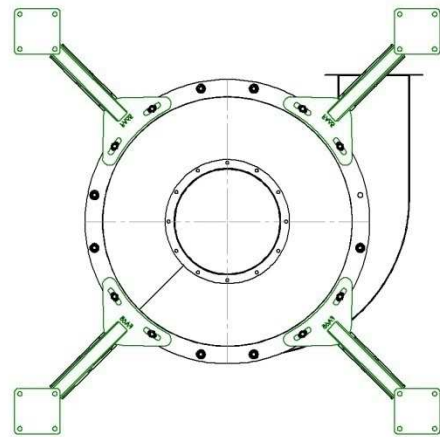

LEG SUPPORT POSITIONING FOR
FA CYCLONES RIGHT SIDE

Step 3: Bolt the top of each leg to the middle flange of the cyclone with the correct fasteners.

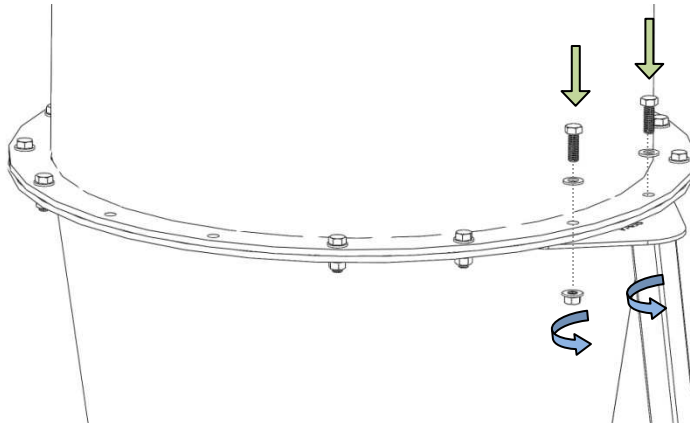

Step 4: Repeat Step 2 and Step 3 to attach the other three leg supports.

Step 5: Loosen all the fasteners from the lower arm of the leg support.

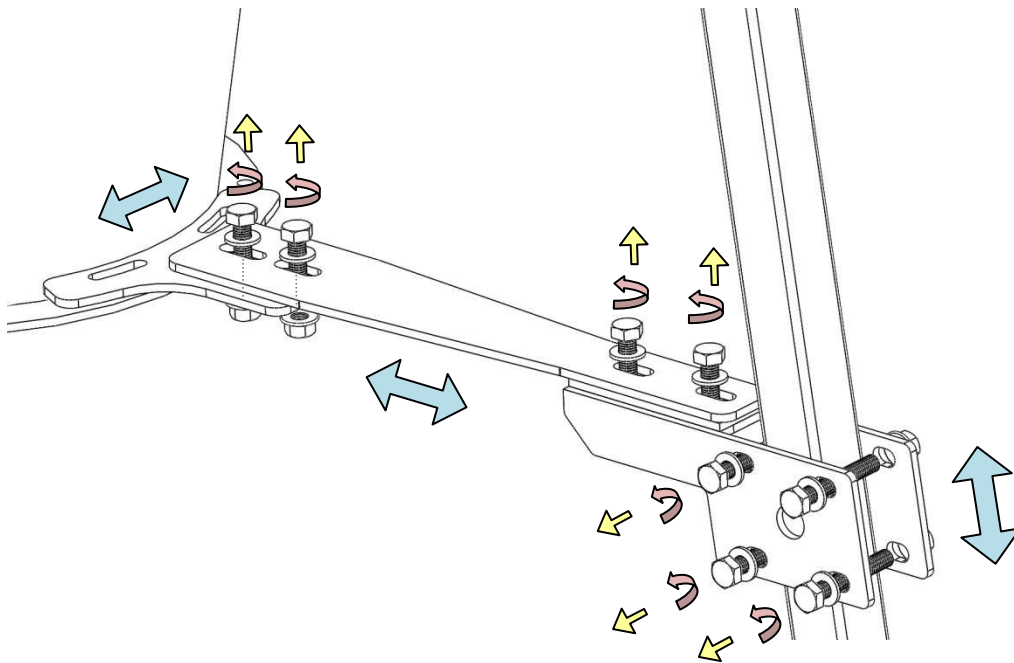

Step 6: Attach the lower arm to the cyclone's hopper lower flange with M10 fasteners.

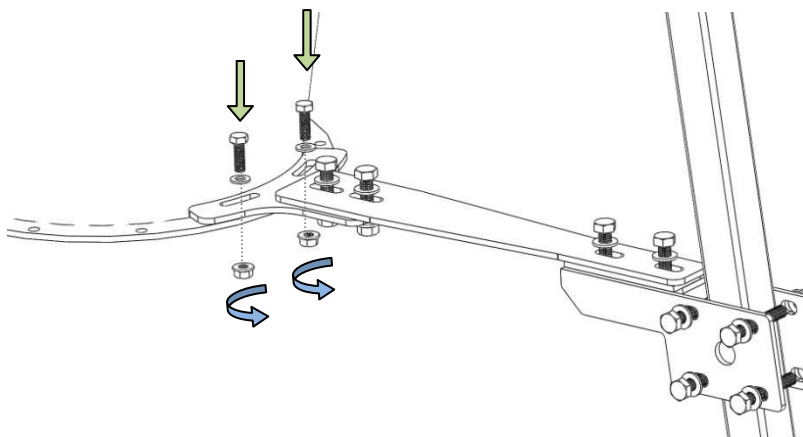

Step 7: Tighten all the loose fasteners for a good fixation.

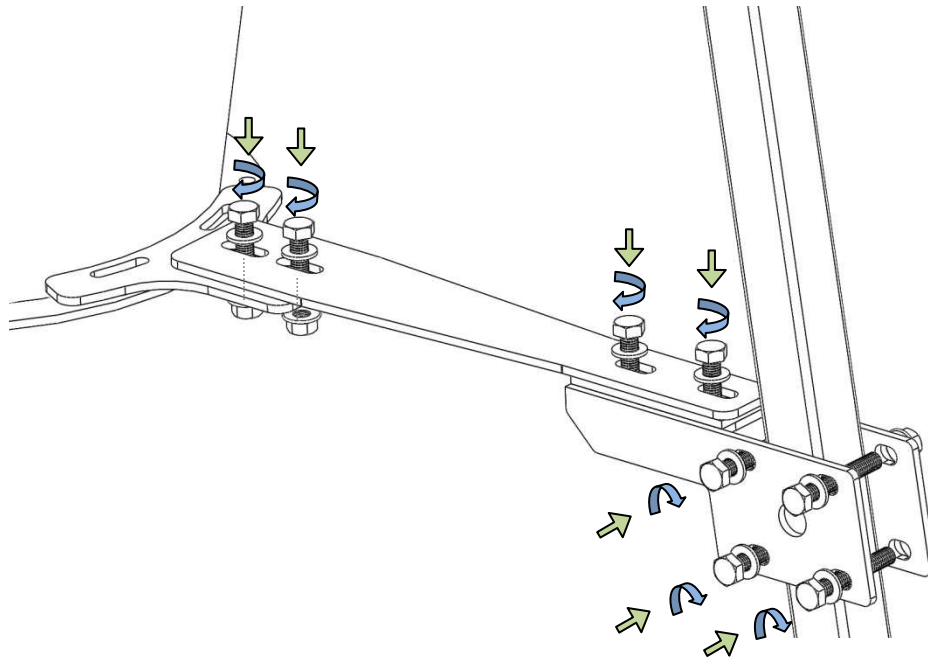

Step 8: Repeat the Step 5, Step 6 and Step 7 for the other leg supports.

Step 9: Anchor the legs to the floor with the correct fasteners.

2.3. Installation of the dustbin

Step 1: Please follow the installation steps in *Chapter 2.2.* for cyclone and legs installation.

Step 2: Remove all fasteners from the lower flange of the cyclone.

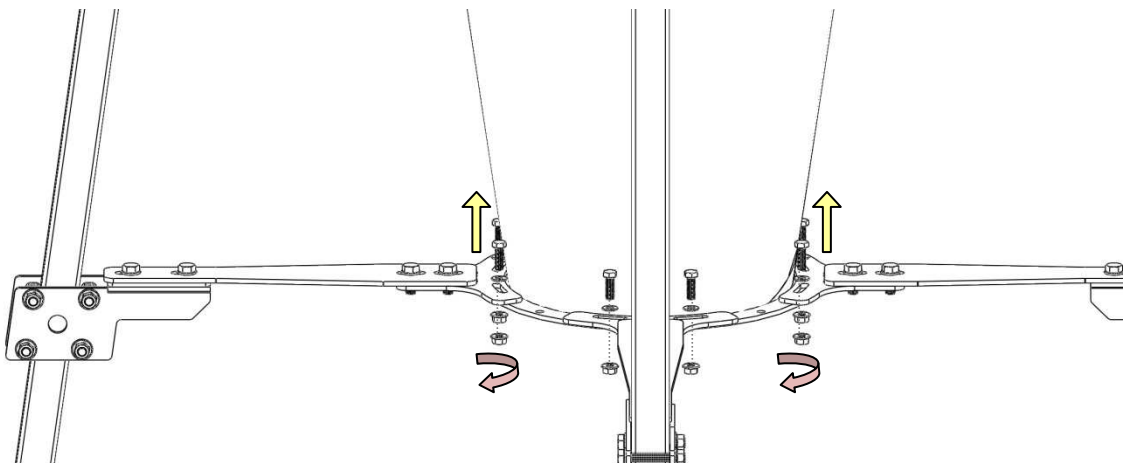

Step 3: Use sealing tape on the connector's flange and connect it to the lower flange of the cyclone with the correct fasteners.

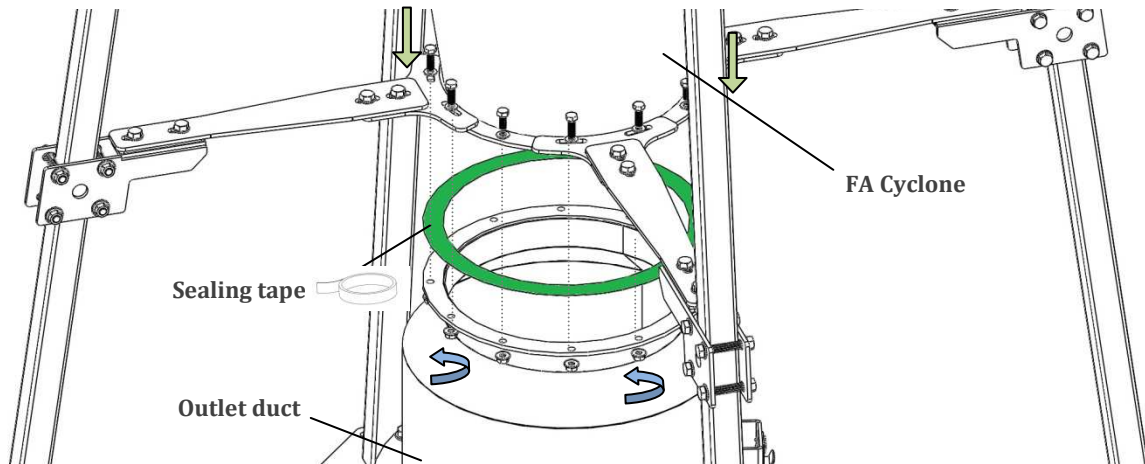

Step 4: Fix the dustbin.

** For dustbins with rigid connection*

- Lock the dustbin to the transition with the three clamps.

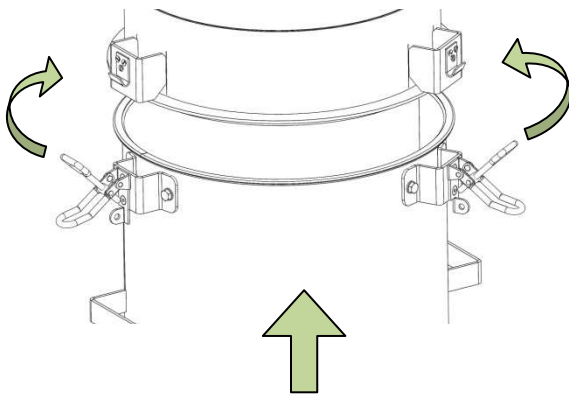

** For dustbins with flexible connection*

- Lock the dustbin to the connector with the lock ring.

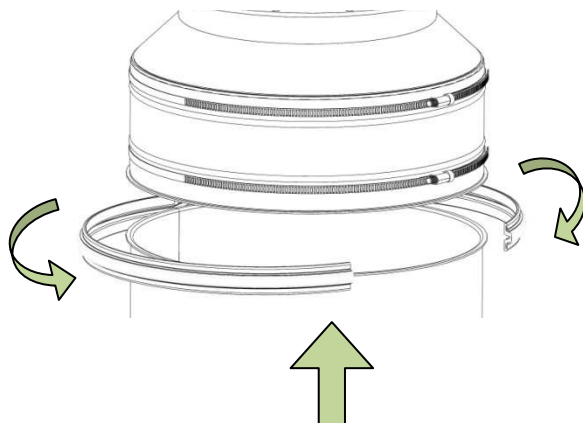

2.4. Removing the dustbin

Step 1: Unlock the dustbin.

** For dustbins with rigid connection*

- Unlock the three clamps from the dustbin.

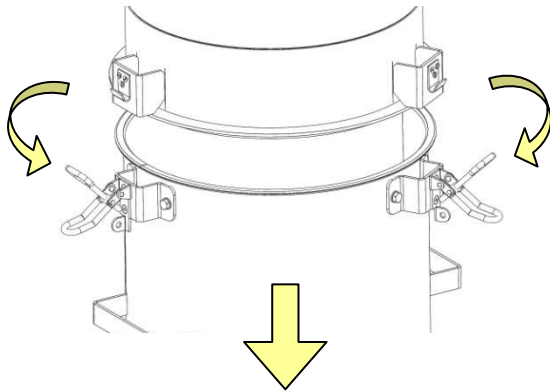

** For dustbins with flexible connection*

- Unlock the lock ring which fixes the dustbin to the connector.

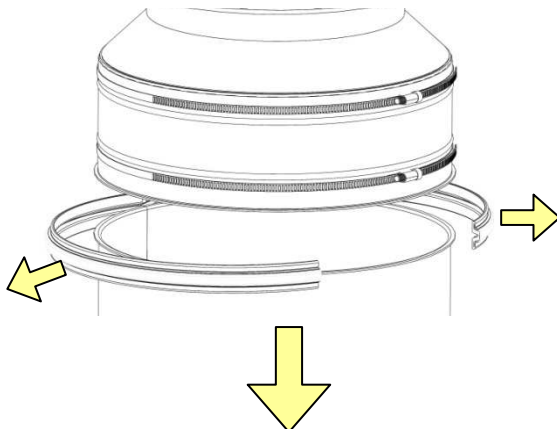

Step 2: Roll the dustbin to the desired location and empty its contents.

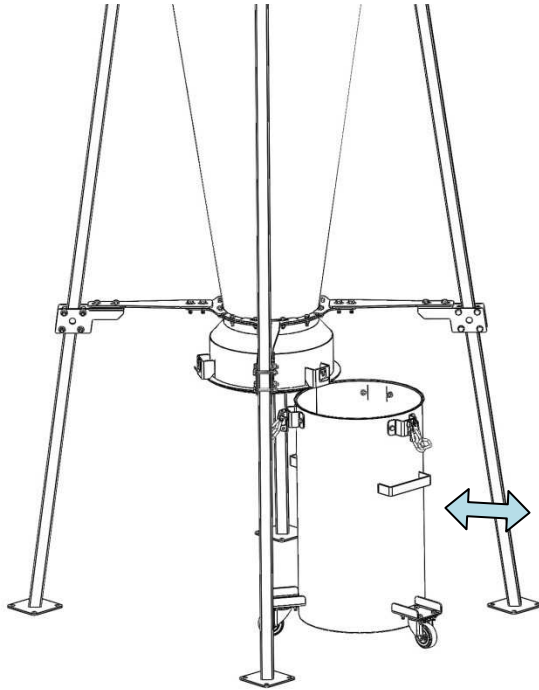

Step 3: Fix the dustbin again. Please follow the *Step 4* in *Chapter 2.3*.

2.5. Installation of the expansion chamber

When using an expansion chamber, extra legs are added under the standard leg support, so that the space left between the floor and the lowest part of the cyclone is always 1 meter.

Step 1: Attach the extra leg support to the standard leg support with M12 fasteners. Repeat this step for the other legs.

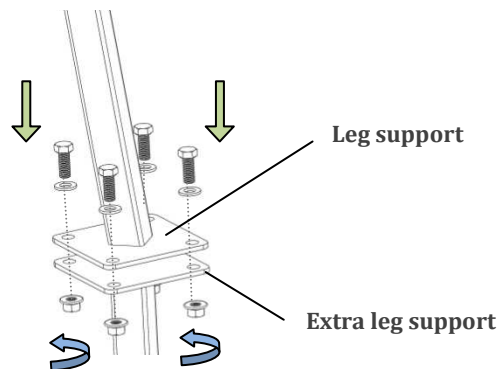

Step 2: For the leg support installation, please refer to *Step 2* to *Step 8* in *Chapter 2.2*.

Step 3: Place the crosspiece onto the extra leg support's profiles.

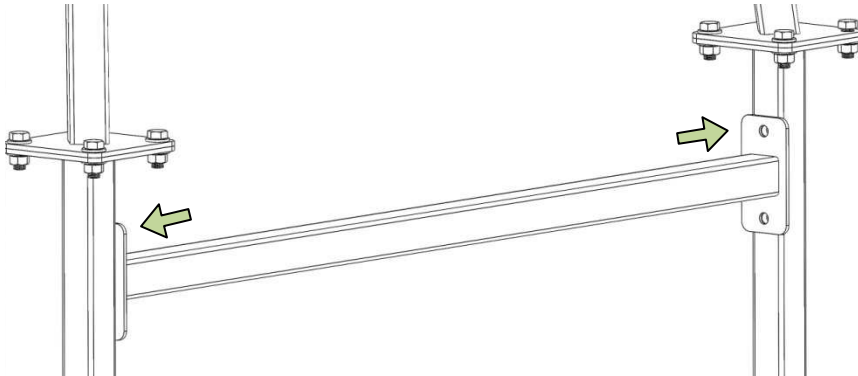

Step 4: Use M10 fasteners to attach the crosspiece to the leg support.

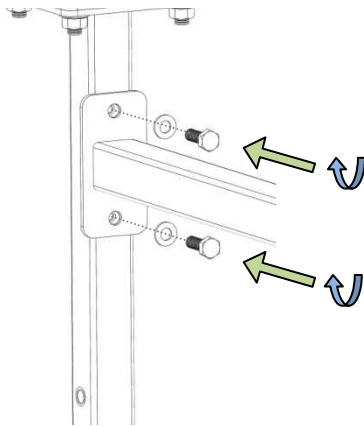

Step 5: Anchor the legs to the floor with the correct fasteners.

Step 6: Attach the expansion chamber by its flange to the lower flange of the cyclone with the correct fasteners.

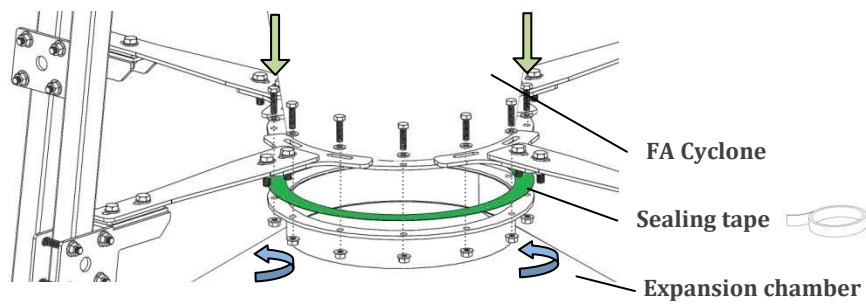

3. MAINTENANCE & TROUBLESHOOTING

Clean the cyclone regularly.

If the dust outlet is blocked, please clean the inside of the cyclone.

Replace any components that are damaged or broken.

3.1. Removing the dustbin transition

Step 1: Unscrew the fasteners which attach the dustbin transition to the cyclone.

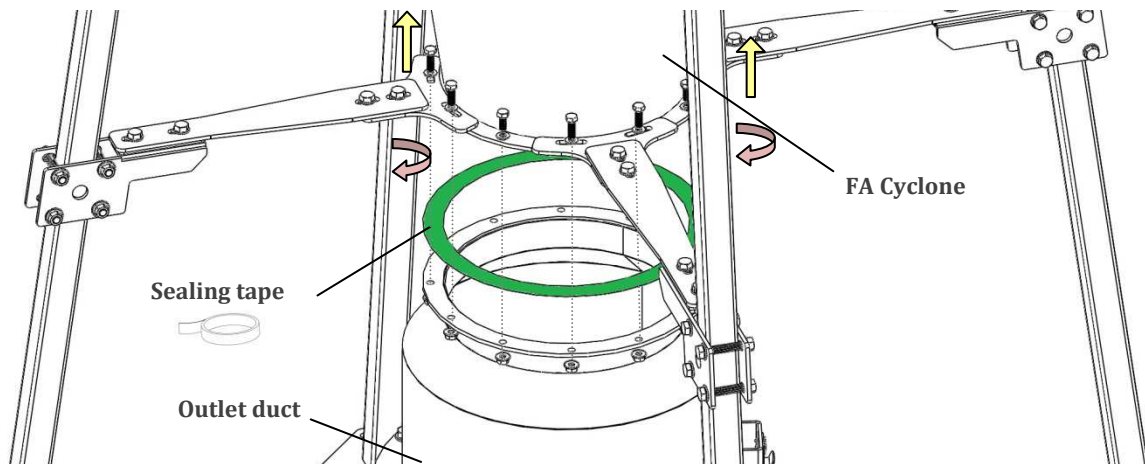

3.2. Replacing the leg support

Step 1: Unfix the leg support from the floor.

Step 2: Unscrew the leg lower arm from the cyclone dust outlet flange.

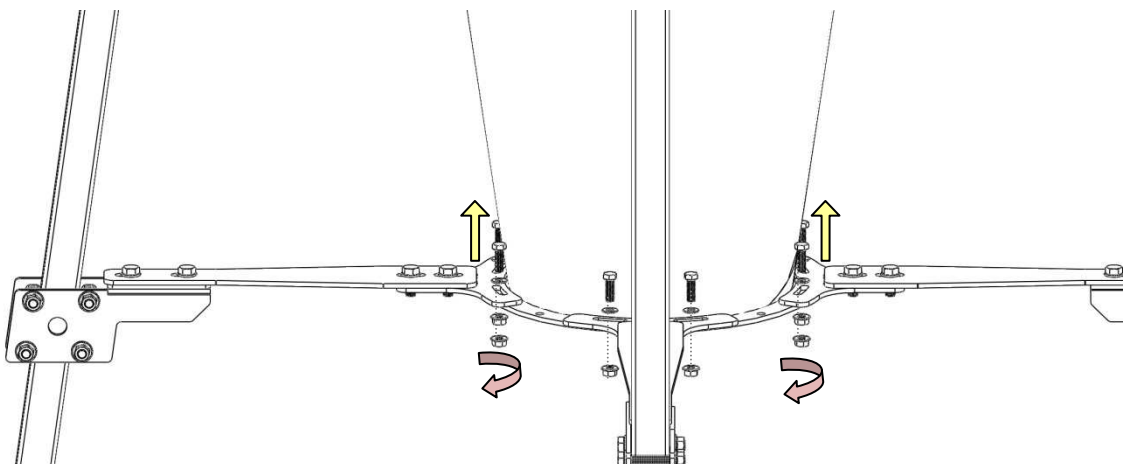

Step 3: Unscrew the fasteners from the higher flange of the cyclones hopper. Remove the leg support.

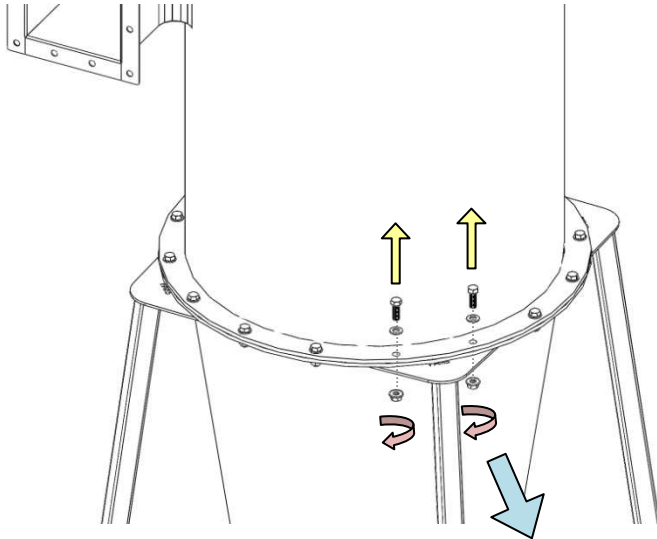

3.3. Replacing a cyclone's part

Step 1: Unscrew the middle part flanges fasteners.

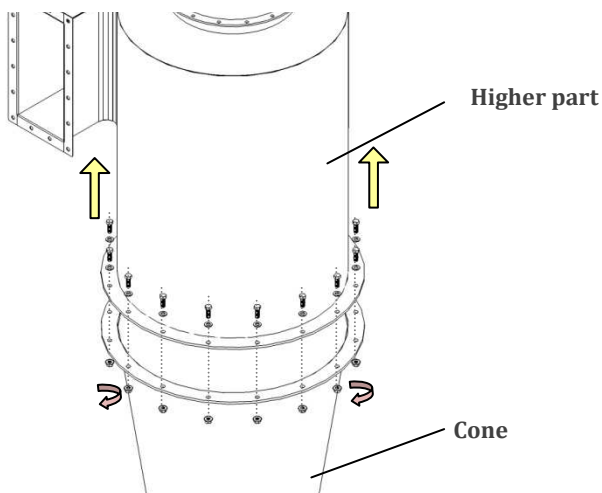

Step 2: Replace the cone or the higher part.

Step 3: Attach the cyclone with the correct fasteners. Use sealing tape to make it airtight.

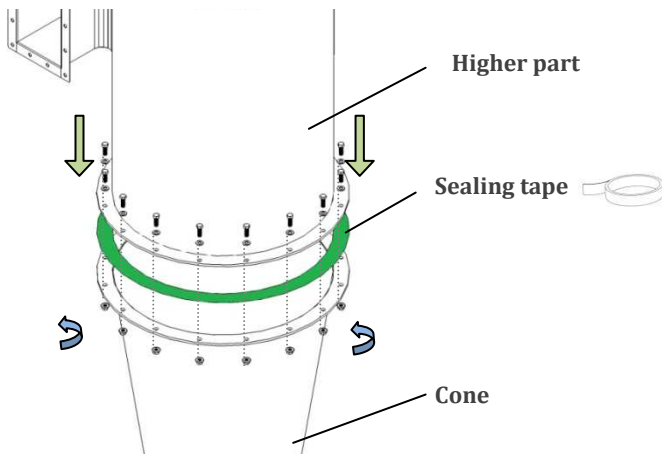

4. DISMANTLING & RECYCLING

When dismantling a unit, be sure to keep in mind the following important information :

As the unit is dismantled, set aside all still functioning parts in order to re-use them on another unit.

You should always separate the different materials depending on their type : iron, rubber, oils, greases, etc...

Recyclable parts must be disposed of in the appropriate containers or brought to a local recycling company.

The rubbish must be collected in special containers with appropriate labels and disposed of in compliance with the national laws and/or local legislations in force.

CAUTION! It is strictly forbidden to dispose of toxic wastes in municipal sewerage and drain systems. This concerns all oils, greases, and other toxic materials in liquid or solid form.

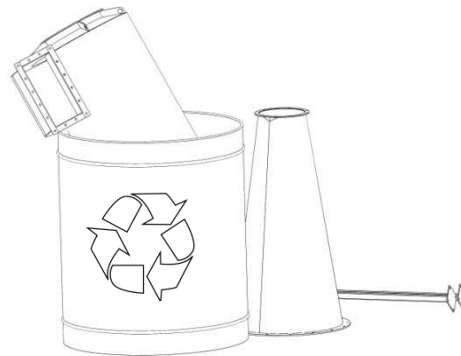

5. SPARE PARTS

For spare parts please contact Formula Air Group.

Formula Air The Netherlands

Bossheweg 36
SX 5741 Beek en Donk
The Netherlands
Tel: +31 (0) 45 492 15 45
Fax: +31 (0) 492 45 15 99

info-nl@formula-air.com
[view Google Map](#)

Formula Air Belgium

Rue des Dizeaux 4
1360 Perwez
Belgium
Tel: +32 (0) 81 23 45 71
Fax: +32 (0) 81 23 45 79

info-be@formula-air.com
[view Google Map](#)

Formula Air Baltic

Televizorių G.20
LT-78137 Šiauliai
Lithuania
Tel: +370 41 54 04 82
Fax: +370 41 54 05 50

info-lt@formula-air.com
[view Google Map](#)

Formula Air France

Zac de la Carrière Doree
BP 105, 59310 Orchies
France
Tel: +33 (0) 320 61 20 40
Fax: +33 (0) 320 61 20 45

info-fr-nord@formula-air.com
[view Google Map](#)

Formula Air Est Agence France

2, rue Armand Bloch
25200 Montbéliard
France
Tel. +33 (0) 91 381 70 71
Fax +33 (0) 381 31 08 76

info-fr-est@formula-air.com
[view Google Map](#)

Formula Air France Agence Ouest

19a rue Deshoulières
44000 Nantes
France
Tel. +33 (0) 89 251 90 75
Fax +33 (0) 251 89 94 06

info-fr-ouest@formula-air.com
[view Google Map](#)

Formula Air France Agence Sud

Chemin de Peyrecave
09600 Regat
France
Tel: +33 561 66 79 70
Fax: +33 567 07 01 09

info-fr-sud@formula-air.com
[view Google Map](#)

Air Formula Russia

Нижний Новгород
Россия
Tel: +7920008 88 75
Fax: +7 (831) 277 85 38

info-ru@formula-air.com
[View Google Map](#)

Formula Air Vietnam

33, Lot 2, Den Lu 1
Hoang Mai District, Hanoi,
Vietnam
Tel: +84 (4) 38 62 68 01
Fax: +84 (4) 38 62 96 63

info@vinaduct.com
www.vinaduct.com
[View Google Map](#)

NOTE : All drawings and references contained within this manual are non-contractual and are subject to change without prior notice at the discretion of the Formula Air group and its partners.