

DANSEP – Separator

Maintenance Manual

Contents

1.	EC DECLARATION OF CONFORMITY	2
2.	INTRODUCTION	3
	You are welcome to contact us for information and comments.....	3
3.	TECHNICAL DETAILS	3
4.	FUNCTIONAL DESCRIPTION	4
	Mechanical structure	4
	Rotary cabinet, lower part	4
	Rotary cabinet, upper part	4
	Rotor	5
	Separation screen	5
	Drive units	5
	Rotation sensor.....	5
	Options	5
5.	MARKINGS.....	5
6.	WARNINGS	6
7.	MOUNTING	6
	Delivery	7
	Storage	7
	Preparation	7
	General mounting	7
	Safety.....	7
	Electrical connection	7
	Start-up	7
	Daily operation.....	8
8.	OPERATION AND MAINTENANCE.....	8
	Separation screen	8
	Rotor	8
	Gear	9
	Motor.....	9
9.	ROTOR SERVICE & REPLACEMENT	9
	DanSep 22, 35 & 50	9
	DanSep 60.....	9
	Replacing the rotor or separation screen	10
10.	NOISE.....	10
11.	TROUBLESHOOTING	11
12.	DISMANTLING & RECYCLING	13
13.	CONTACTS	14

1. EC DECLARATION OF CONFORMITY

Manufacturer: **Moldow A/S**

**Jørgen Hansens Vej 1
DK-6670 Holsted**

Hereby states that the following product:

Machine : DanSep

Type : xx-xx

is in compliance with the following provisions:

EC directive on machinery 2006/42/EC of 17th May 2006 with specific reference to exhibit I of the directive concerning important safety and health requirements in connection with construction and manufacture of machines

EMC-directive 2014/30/EU of 26th February 2014 on the harmonization of the laws of the Member States relating to electromagnetic compatibility

LVD-directive 2014/35/EU of 26th February 2014 on the harmonization of the laws of the Member States relating to the making available on the market of electrical equipment designed for use within certain voltage limits

And furthermore declares that the following harmonized standard has been used.

EN ISO 12100:2011 **General principles for design - Risk assessment and risk reduction**
EN 60204-1:2006 **Electrical equipment of machines**

Managing Director



Preben Hansen

Holsted, the 15-01-2015

2. INTRODUCTION

We are pleased by the fact that you have chosen this product. In order to attain optimum usage of the properties of the DanSep separator it is presumed that the user reads this manual thoroughly.

Read this manual thoroughly before commissioning of a DanSep separator. Please pay special attention to the section concerning maintenance, as correct maintenance of the DanSep separator is a prerequisite for trouble-free operation.

The user of the DanSep separator must ensure that the operator, service personnel and others who have access to the machine is instructed on the proper use and handling of the machine.

You are welcome to contact us for information and comments.

3. TECHNICAL DETAILS

	DS 22	DS22 HP	DS 35	DS 35 HP	DS 50	DS 50 HP	DS 60	DS 60 HP
Net weight (kg)	530	540	700	725	1155	1180	1325	1350
Voltage 50 Hz, 3 phase 60 Hz, 3 phase	230/400 276/480	230/400 276/480	230/400 276/480	230/400 276/480	230/400 276/480	230/400 276/480	230/400 276/480	230/400 276/480
Frequency (Hz)	50/60	50/60	50/60	50/60	50/60	50/60	50/60	50/60
Motor power kW, 50 Hz kW, 60 Hz	1,5 1,8	1,5 1,8	2,2 2,6	2,2 2,6	3,0 3,6	3,0 3,6	3,0 3,6	3,0 3,6
Rotor rpm 50 Hz 60 Hz	15,5 14,9	15,5 14,9	15,5 14,9	15,5 14,9	9,2 9,3	9,2 9,3	9,2 9,3	9,2 9,3
Capacity at 100% load (m ³ /h)	600	600	1000	1000	1400	1400	1680	1680
Max. volume flow (m ³ /h)	22000	22000	35000	35000	50000	50000	60000	60000
Pressure drop at max vol. (Pa)	500	500	500	500	500	500	500	500
Max. under pressure (Pa)	2500	6000	2500	6000	2500	6000	2500	6000
Max. over pressure (Pa)	3500	4000	3500	4000	3500	4000	3500	4000



4. FUNCTIONAL DESCRIPTION

The DanSep separator is used for separation of air conveyed material.

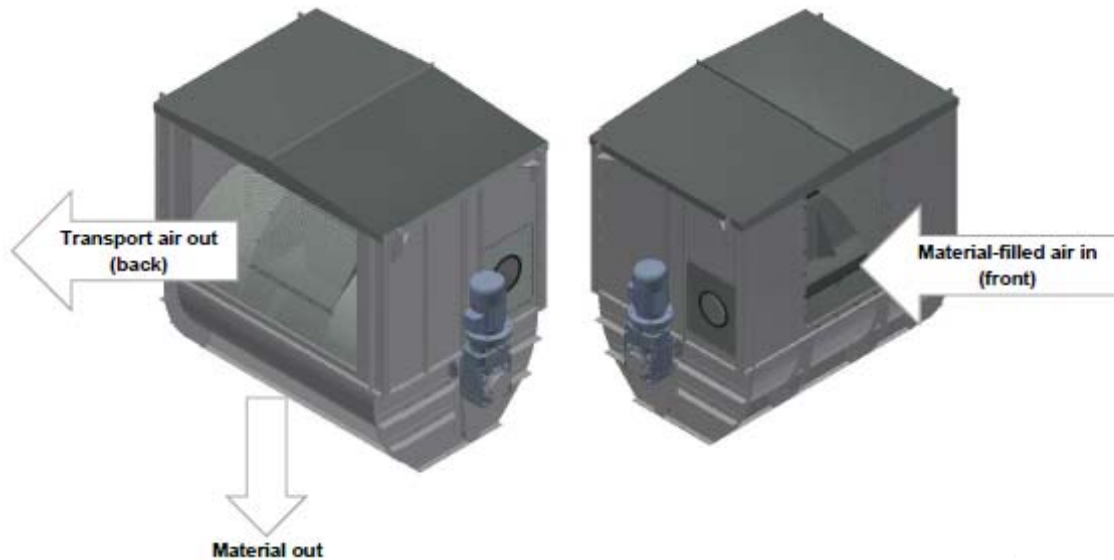

Mechanical structure

Functionally the separator consists of the following main elements:

- Roof for outdoor installation (optional)
- rotary cabinet, Upper housing
- Separating screen
- Rotor
- Drive unit
- rotary cabinet, lower housing
- rotation sensor



Rotary cabinet, lower part

The rotary cabinet is made of painted mild steel plates. The gables are equipped with a slit and a filler piece to make sure that the rotor can be removed.

The DanSep 22, 35 & 50 have side plates and curved back welded together. The curved front plate is bolted on the body to ensure easy access to change the lamellas during maintenance.

The DanSep 60 has the entire lower part welded together.

Rotary cabinet, upper part

The upper part of the rotary cabinet of the HP models is made of painted mild steel plates and consists of a perforated housing while in the standard models is made of galvanized plates.

The injection chamber and is made of electrogalvanized plate with a perforation. The upper part of the rotary cabinet is in one piece and bolted to the lower part. The perforated rotary cabinet is unpainted.

An inspection hatch with window is installed on each side of the unit and all housing panels are equipped with rubber gaskets for easy assembly during maintenance.

Rotor

The rotor is composed of 6-chambers with laminar holders in hot-galvanized plate. Longitudinal lamellas and lamellas towards gables are in Neoprene-rubber. The laminar holders are reinforced by triangles in each chamber. The rotor is suspended by two flange bearings equipped with extra dust tight rings.

Separation screen

The separation screen is built from perforated mild steel plates. The screen divides the upper housing into an injection chamber and a clean air chamber.

The screen is one piece and fastened to the upper and lower part of the housing by bolts.

Drive units

A hole-shaft gear is mounted on the rotary shaft.
A velocity control is mounted on the rotary shaft opposite the gear.

Rotation sensor

The rotor shaft is equipped with a rotation sensor, located opposite the drive unit

Options

Rain protection. An optional roof in galvanized steel can be applied on the top of the unit for outdoor installations.

5. MARKINGS

The DanSep separator is marked according to current requirements. The type plate states type, order number and year of manufacture.

MOLDOW

Moldow A/S · Jørgen Hansens Vej 1 · DK-6670 Holsted
mail@moldow.com · www.moldow.com · Tlf.: +45 75 39 26 44 · Fax.: +45 75 39 31 55

Type

No.

Order

Year





6. WARNINGS

WARNING - WARNING - WARNING !!!

THE POWER SUPPLY TO THE PLANT MUST BE DISCONNECTED PROPERLY AND SECURED AGAINST RECLOSING BEFORE ANY KIND OF MAINTENANCE MUST BE COMMENCED!

The DanSep separator contains rotating parts.

Therefore, it is not allowed to connect the separator electrically until ducts are connected on both the suction as well as the exhaust side of the separator.

The air outlet is only connected to the clean air chamber of the separator. Here the rotor is covered by a perforated shield.

The belt drive is protected by a shield to provide that fingers cannot get jammed.

7. MOUNTING

Important:

Always wear the required safety equipment.

Head protection required when lifting the separator.



Always use correct tools and equipment in connection with the mounting.

The national safety rules in force must be observed.

If lifting is necessary, only approved lifting equipment must be used.

Persons must not be present under hanging load – DANGER ZONE !!!

Delivery

The DanSep separator is delivered assembled as a complete unit on a pallet.

Storage

Until mounting is commenced, all parts of the DanSep separator must be stored under conditions preventing rusting, corrosion, decomposition or deformations.

Preparation

Check all delivered parts for possible transport damages before mounting is commenced.
Check that access conditions and the necessary space around the DanSep separator are correct.
It must also be checked that the base the DanSep separator is placed on can bear the actual load.

General mounting

The DanSep separator must be mounted on a stable surface capable of withstanding the separator load. In some cases, the separator can be supported/suspended from the square or angle profiles on the side plates of the lower separator housing. The lifting eyes on the support housing are only intended for lifting the upper housing and will not support the full weight of the unit.

The connected ducts need to be supported independently and not on the separator.

Mounting must only be performed by trained personnel and in accordance with the mounting instructions. Necessary personal protective equipment must be used.

Safety

Most of the components that the DanSep separator is built of are cut and bent thin sheet. It cannot be avoided that some of the plate edges become sharp during manufacturing.

Electrical connection

Electrical connection must only be carried out by an authorized electrician according to current national legislation.

The motor may not be electrically connected before the injection and outlet ducts as well as duct for transport of the rough waste have been connected.

The rotation sensor must be connected, and its set point must be so close to the rotor rotations (please refer to the technical information) that the separator stops in case of blocking.

There must be a service switch near the separator.

Start-up

When the mounting is accomplished and the motor connected electrically, DanSep may be started. Make sure that the direction of rotation is correct.

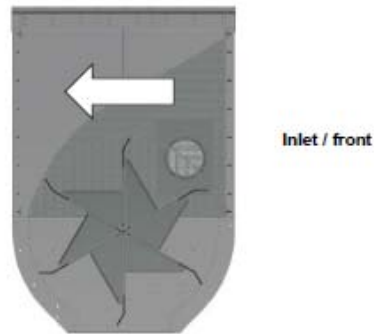

After an hour of operation, tighten up belts, supports and the gear.

Daily operation

No special comments. The separator should run smoothly on a daily operation but always check for material build-up.

8. OPERATION AND MAINTENANCE

WARNING - WARNING - WARNING !!!

The DanSep separator is operated, together with the rest of the plant from the central control panel. Before performance of service / maintenance the separator and the connected plant **MUST** be disconnected at the central control panel. Furthermore, it must be ensured that the fan has stopped its rotation!



Important:

Always wear the required safety equipment.
Respiratory protection is required for maintenance.

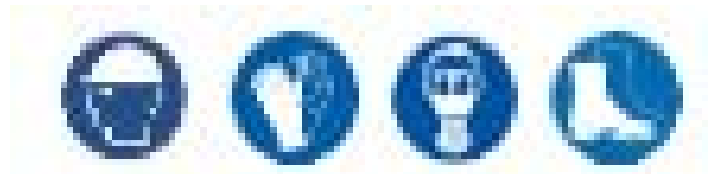

The outside of the separator needs no maintenance.

Inspection to be made after every 1.000 hours of operation, and at least 2 times a year the following must be tested:

Separation screen

The cabinet must be tested for dust collections through the inspection glass. Remove the inspection doors if heavy dust collections are discovered and vacuum clean the cabinet.

Rotor

Lubricate the flange bearing with universal grease. If there is dust in the bearing, exchange the felt seals behind the flange bearing.

If the flange bearing makes any jeering sound, it has to be exchanged.

If the rubber lamellas on the rotor are worn out, they have to be exchanged.

Gear

The gear is lubricated for life with lubricating oil. Temperature area -30°C - +50°C. The gear needs no maintenance. Please refer to the supplier maintenance guide for further information.

Motor

Reference to "Maintenance Instructions for Electro-motors" from the supplier.

9. ROTOR SERVICE & REPLACEMENT

DanSep 22, 35 & 50

To access the rotor for service such as replacement of the lamellas or a complete rotor fin, dismantle the front plate on the lower separator housing (due to the weight, two people are required)

To rotate the rotor, dismantle the fan shroud on the motor. This will give access to a bolt on the end of the motor shaft which can be rotated using either a wrench or a non-impact driver.

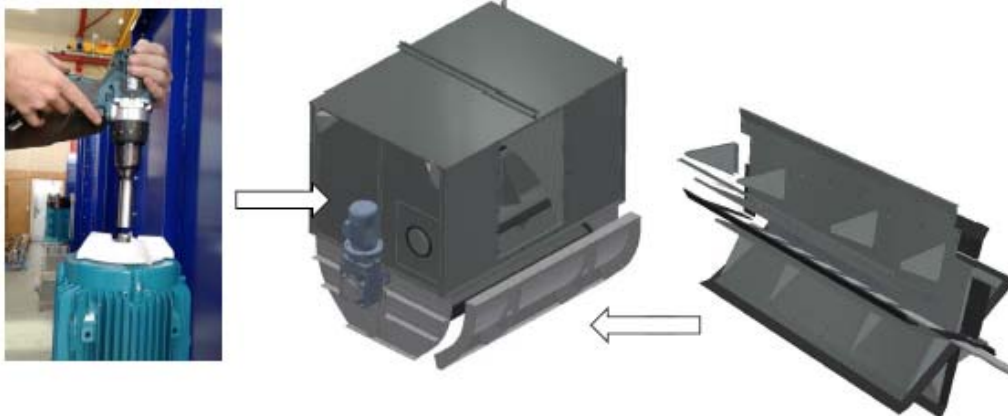

DanSep 60

Due to the size and to ensure stability, the lower separator housing is welded in one piece.

During maintenance or replacement of the rotor, it is necessary to remove the bolts between the upper and lower housings and remove the ducting connected to the separator.

After that, the upper housing can be removed, and maintenance work on the rotor can be carried out.

This method requires a crane or other approved lifting equipment.



If lifting the entire upper housing with a crane is not an option, the plates can be dismantled and removed one by one.

After this, the separation plate can be removed allowing access to the rotor.

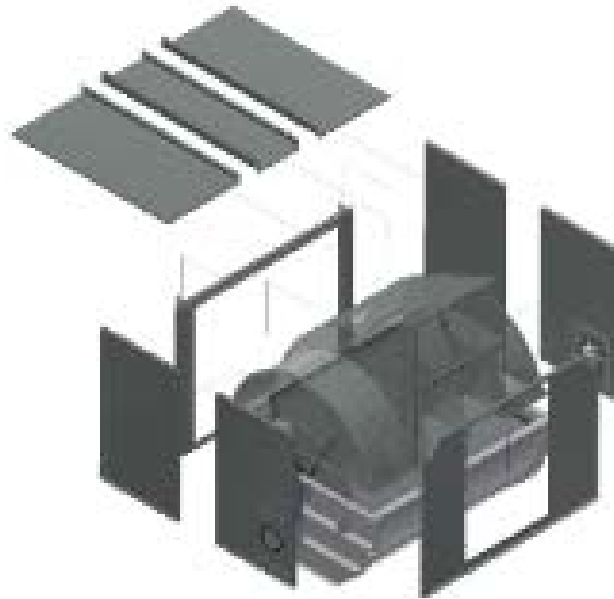

Replacing the rotor or separation screen

To replace the rotor or perforated separation screen, one of the access methods mentioned above pertaining to the DanSep 60 must be used for all DanSep models.

Once the upper separator housing has been removed, you will have access to replace the separation screen.

When replacing the rotor, it will be necessary to dismantle the drive unit, flange bearings and dust seals to allow removal of the rotor.

Mounting of the rotor is carried out in the reverse order.

We recommend replacing the flange bearings and felt dust seal whenever the rotor is replaced.

10. NOISE

The noise ratio of the component in our scope of supply in connected condition and without media is below 70 dB(A) measured at a distance of 1 meter from the component.

Noise from transported media or fan are not included.

Important:

A higher noise level may occur depending on local conditions, like a machine which is connected with other machines. In this case separate measurements may be required.

If the total noise level in the area exceeds 80 dB(A), hearing protection must be used.

11. TROUBLESHOOTING

Failure	Possible causes	Proposed solutions
Separator switches off thermally	<ul style="list-style-type: none"> - Foreign body jammed - Rotor frozen - Gear motor defective - Rotor defective - Motor protection set incorrectly - Fuse defective - Big voltage drop in power supply 	<ul style="list-style-type: none"> - Remove foreign body - Thaw the rotor - Replace the gear motor - Replace the rotor - Adjust the motor protection - Replace the fuse - Replace cables to larger gauge
Separator is not running	<ul style="list-style-type: none"> - Working switch is off - Motor protection switched of thermally - Conditions of operation are not met in the control system - Fuse defective - Rotary guard defective 	<ul style="list-style-type: none"> - Stop the installation, switch on the working switch - See " Failure - Separator switches off thermally" - Investigate why conditions are not met - Replace the fuse - Replace the rotary guard
Separator makes "screaming" sound	<ul style="list-style-type: none"> - Foreign body got stuck - Rotor defective - Flange bearing defective 	<ul style="list-style-type: none"> - Remove foreign body - Replace defective part - Replace flange bearing
The material will not pass the separator without accumulation	<ul style="list-style-type: none"> - Material load to large - Settling velocity of material less than expected - The material accumulates in lumps which cannot pass - The material is not removed fast enough at the outlet of the separator 	<ul style="list-style-type: none"> - Reduce material feed load - Adjust the production machine to change the flow of material - Adjust the production machine to change the flow of material - Check the drop chute for jams
Increase pressure in in drop chute	<ul style="list-style-type: none"> - Defective lamellas 	<ul style="list-style-type: none"> - Exchange lamellas or entire rotor
Material pass to the filter	<ul style="list-style-type: none"> - Defective separation screen 	<ul style="list-style-type: none"> - Replace separation screen

DS22(HP)

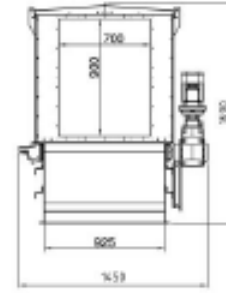
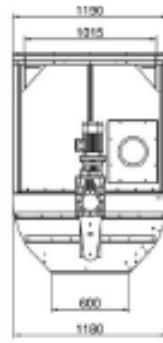
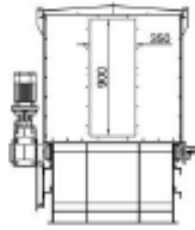

DS35(HP)

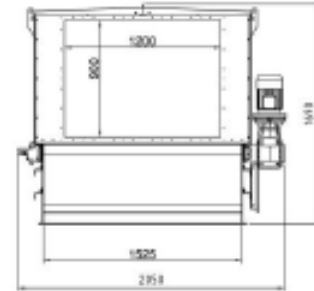
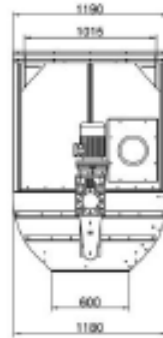

DS50(HP)

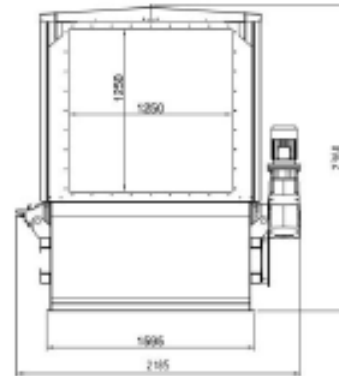
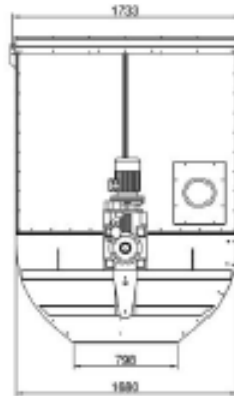
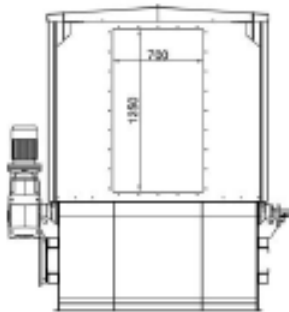

DS60(HP)

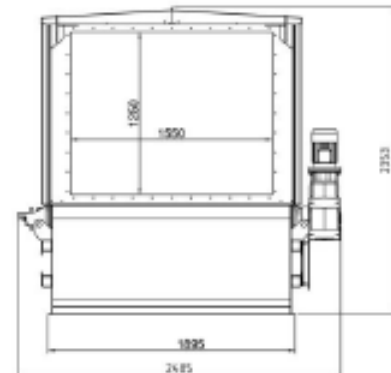
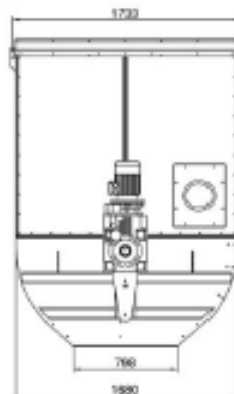
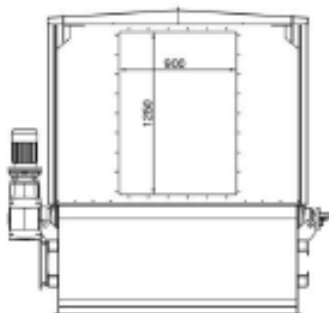

12. DISMANTLING & RECYCLING

When dismantling a unit, be sure to keep in mind the following important information :

As the unit is dismantled, set aside all still functioning parts in order to re-use them on another unit.

You should always separate the different materials depending on their type : iron, rubber, oils, greases, etc...
Recyclable parts must be disposed of in the appropriate containers or brought to a local recycling company.

The rubbish must be collected in special containers with appropriate labels and disposed of in compliance with the national laws and/or local legislations in force.

CAUTION! It is strictly forbidden to dispose of toxic wastes in municipal sewerage and drain systems. This concerns all oils, greases, and other toxic materials in liquid or solid form.

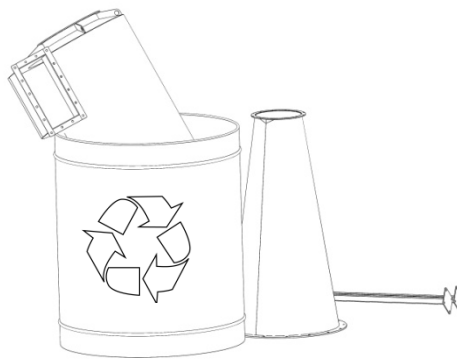

13. CONTACTS

For spare parts please contact Formula Air Group.

Formula Air The Netherlands

Boscheweg 36
SX 5741 Beek en Donk
The Netherlands
Tel: +31 (0) 45 492 15 45
Fax: +31 (0) 492 45 15 99

info-nl@formula-air.com
[view Google Map](#)

Formula Air Belgium

Rue des Dizeaux 4
1360 Perwez
Belgium
Tel: +32 (0) 81 23 45 71
Fax: +32 (0) 81 23 45 79

info-be@formula-air.com
[view Google Map](#)

Formula Air Baltic

Televizorių G.20
LT-78137 Šiauliai
Lithuania
Tel: +370 41 54 04 82
Fax: +370 41 54 05 50

info-lt@formula-air.com
[view Google Map](#)

Formula Air France

Zac de la Carrière Doree
BP 105, 59310 Orchies
France
Tel: +33 (0) 320 61 20 40
Fax: +33 (0) 320 61 20 45

info-fr-nord@formula-air.com
[view Google Map](#)

Formula Air Est Agence France

2, rue Armand Bloch
25200 Montbéliard
France
Tel. +33 (0) 381 91 70 71
Fax +33 (0) 381 31 08 76

info-fr-est@formula-air.com
[view Google Map](#)

Formula Air France Agence Ouest

19a rue Deshoulières
44000 Nantes
France
Tel. +33 (0) 251 89 90 75
Fax +33 (0) 251 89 94 06

info-fr-ouest@formula-air.com
[view Google Map](#)

Formula Air France Agence Sud

Chemin de Peyrecave
09600 Regat
France
Tel: +33 561 66 79 70
Fax: +33 567 07 01 09

info-fr-sud@formula-air.com
[view Google Map](#)

Air Formula Russia

Нижний Новгород
Россия
Tel: +7 (499) 609 23 54
Fax: +7 (831) 277 85 38

info-ru@formula-air.com
[View Google Map](#)

Formula Air Vietnam

33, Lot 2, Den Lu 1
Hoang Mai District, Hanoi,
Vietnam
Tel: +84 (4) 38 62 68 01
Fax: +84 (4) 38 62 96 63

info@vinaduct.com
www.vinaduct.com
[View Google Map](#)

NOTE : All drawings and references contained within this manual are non-contractual and are subject to change without prior notice at the discretion of the Formula Air group and its partners.