

**M18 inductive rotation detector for RVA & RVB Rotary valves**

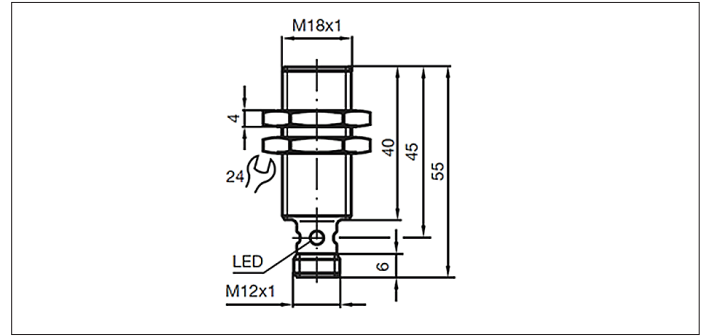

**M18 inductive rotation detector for RVA & RVB rotary valves**

Special bolt-shaped inductive rotation detector for rotation disks on the front of the rotary valve models RVA and RVB.

It detects if the rotation disk is turning by measuring the empty/full spaces on the rotation disk surface.

This detector is produced according to the following harmonized directives/standards :

- EN 60947-5-6:2000, IEC 60947-5-6:1999 ; NAMUR compliance,
- NE 21:2007 ; Electromagnetic compatibility,
- Standards EN 60947-5-2:2007, EN 60947-5-2/A1:2012, IEC 60947-5-2:2007, IEC 60947-5-2, AMD 1:2012,
- Usable up to SIL 2 according to IEC 61508.

**Material**

Stainless steel 1.4305 / AISI 303 with multihole yellow LED.

**Type**

- Output: NAMUR (normally closed)
- Nominal voltage : 8.2 V (Ri approx. 1 kΩ)
- Operational current : min. 2.2 mA
- Rated operating distance ( $s_n$ ) : 8 mm
- Protection : reverse polarity
- Protection Level : IP 66 / IP67
- Working temperature : -25°C up to +100°C
- Weight : 80 g.

**Options**

- ATEX version (for rotary valve range RVA-X)
- Range of accessories

