

**BAHF Pneumatic trouser diverters 45° with seal**

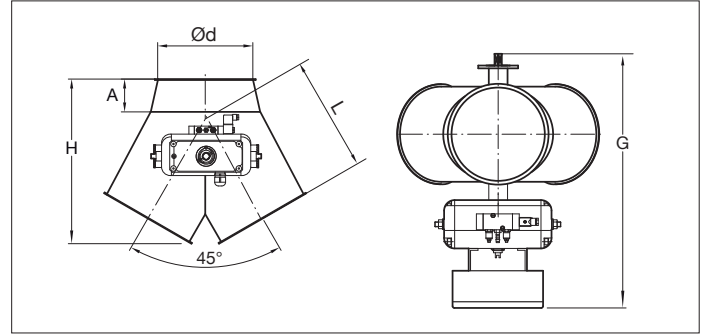

**BAHF Pneumatic trouser diverters 45° with seal**  
Full welded round pneumatic trouser diverter with interior collar and silicone seal for bulk transport to silos, containers and such.

The change in direction of the material is operated by a pneumatic rotating actuator connected to a bistable 5/2 solenoid valve, 24V DC with limit switches. The inner plate is mounted on two ball bearings for smooth running.

These diverters are designed to be used for falling material and light pneumatic transport (for example wood chips, polystyrene, etc.) in vertical ducting.

**Material**  
2.00 mm powder coated black steel in RAL 7032.  
Electrostatically conductive and food-safe powder coating thickness of 30 to 60 µm.  
Temperature resistance up to +80°C.  
Silicone seal.  
Pneumatic actuator working temperature range -15°C to +50°C.

**Type**  
Rolled and welded plates with 6 mm edges for lock rings.

- Options**
- FDA and EU compliant food-grade quality
  - with other seal material
  - stainless steel execution
  - equipotential equalization or ATEX
  - 230V AC solenoid valve
  - other colors
  - 3 mm sheet thicknesses, depending on material and diameter
  - other types of edges or connections

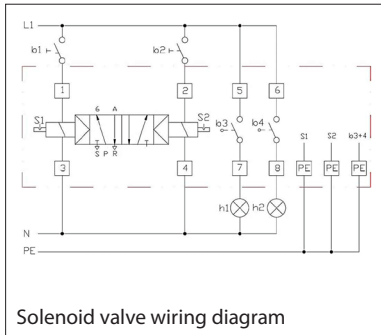

**!** Max. air pressure in solenoid valve : 8 Bar.

**Diverter with seal**

Ø d mm	Code	A mm	G mm	H mm	L mm	Thickness mm	Weight kg
100	BAHF000125	35	455	228	185	2.00	14.00
120	BAHF000126	40	475	276	228	2.00	15.00
150	BAHF000127	50	505	330	269	2.00	18.00
175	BAHF000128	50	530	373	310	2.00	21.00
200	BAHF000129	50	575	415	350	2.00	24.00
250	BAHF000130	70	625	507	418	2.00	30.00
300	BAHF000131	80	685	599	497	2.00	36.00
350	BAHF000132	100	735	671	547	2.00	42.00
400	BAHF000133	120	785	815	667	2.00	48.00