



Cartridge cyclo-filter

CACF

Maintenance manual (EN)

As of 2019 - V1.0-2021

Content

1.	Introduction	3
1.1.	EC- declaration of incorporation	4
2.	General description.....	5
3.	Functioning	5
3.1.	Daily maintenance.....	5
4.	Unit condition during operation	5
5.	Intentional / unintentional application	6
5.1.	Max. top load for cyclone filter type CACF-T-A:	6
6.	Mounting	6
6.1.	Filter placement	6
6.2.	Electrical connections.....	8
6.3.	Compressed air connection.....	8
6.4.	Ducting connection	8
6.5.	Rotary valve (optional).....	8
6.6.	Adjustments	8
6.7.	Differential pressure control	9
6.8.	Alarm on EN 15012-1 units.....	9
7.	Noise damping	9
8.	Maintenance.....	9
8.1.	Cartridge replacement	9
8.2.	Cartridge cleaning	10
8.3.	Jet valve exchange / repair.....	10
9.	After maintenance	10
10.	Differential pressure control - type ECOMATIC-S	11
10.1.	General description	11
10.2.	General features	11
10.3.	Technical features timer.....	11
10.4.	Technical features Active Analog Output (optional).....	11
10.5.	Dimensions and features of Ecomatic box	12
10.6.	Layout – Legend Board Ecomatic-S	12
10.7.	Layout – Legend Delta-P Board Ecomatic-S.....	15
10.8.	Ecomatic-S Power Supply	15
10.9.	Electro-valves Connection Scheme	16
10.10.	Display visualization.....	18
10.11.	Error visualization	19
10.12.	Preliminary Procedures.....	19
10.13.	Programming Parameters.....	20
10.14.	Ecomatic-S Function	21
10.15.	Delta-P Tubes Connection Scheme	21
10.16.	Pressure Zero Setting.....	22
10.17.	Active Analogical Output Functioning (optional)	22
10.18.	Relay Output Functioning	24
10.19.	Post-Cleaning Functioning	25
10.20.	Precoating Functioning	25
11.	Dismantling and recycling.....	26
12.	Maintenance log.....	26
	Contacts.....	27

1. Introduction

This manual cannot be reproduced, even partially, without prior written consent by Formula Air Group. Every step of the filter range has been deeply analyzed by Formula Air Group in the expected area during the design, construction, and user manual creation. However, it is understood that nothing can replace the experience, training and good sense of those professionals who work with the device.

Ignoring the cautions and warning from the present user manual, using improperly parts or the whole device supplied, using unauthorized spare parts, manipulating the device by non-qualified personnel, violation of any safety norm regarding design, construction and use expected by the supplier, exempt Formula Air Group from all responsibility in case of damages to people or properties.

Formula Air Group does not take any responsibility for the non-observance of the user about the preventive safety measures presented in this user manual.

Failure to comply with the requirements of the user manual or incorrect use of the filter during operation can lead to the damage of the filter and improper functioning of the filter itself. This will result in termination of the warranty on the item and will release the manufacturer from any liability.

Warranty

Regarding to the device's warranty, see the sales general condition.

Attention !

All drawings and references contained within this user manual are non-contractual and are subject to change without prior notice at the discretion of the Formula Air Group and its partners.

Copyright © Formula Air.

1.1. EC- declaration of incorporation

EC-Declaration of Incorporation for Partly Completed Machinery

Machinery Directive 2006/42/EC Annex IIB

The undersigned manufacturer and authorized for the elaboration of technical documentation for partly completed machinery and by due request hand over the technical dossier to the national authorities :

Manufacturer: v.Aa.Gram A/S
Klintevej4,6100Haderslev,Denmark
Tel.:+457452 30 75,Fax:+45745301 64

The undersigned hereby declare that:

Partly completed machinery: Cyclone filter

ATEX ZONE : Zone 21 untreated air II 2 D – Zone 22 clean air II 3 D

CACF-A 39	CACF-T-A 39	CACF-V-A 52 H
CACF-A 52	CACF-T-A 52	CACF-V-A 78 H
CACF-A 52 H	CACF-T-A 52 H	CACF-V-A 104 H
CACF-A 78 H	CACF-T-A 78 H	CACF-V-A 130 H
CACF-A 104 H	CACF-T-A 104 H	CACF-V-A 182 H
CACF-A 130 H	CACF-T-A 130 H	CACF-V-A 234 H
CACF-A 182 H	CACF-T-A 182 H	
CACF-A 234 H	CACF-T-A 234 H	
CACF-A 260 DH	CACF-T-A 260 DH	
CACF-A 364 DH	CACF-T-A 364 DH	
CACF-A 468 DH	CACF-T-A 468 DH	

Was manufactured in conformity with the following essential health and safety requirements in the Machinery Directive 2006/42/EC Annex1:

The following harmonized standards were used:

ISO 14121
EN/I.S013857
EN60204

The partly completed machinery may not be put into service until the final machinery into which it is to be incorporated has been declared in conformity with all relevant health and safety requirements in the Machinery Directive 2006/42/EC and other relevant Directives

Position : XX
Name : XX
Company : V.Aa.Gram A/S

Date : XX.XX.XXXX

XXX

(Signature)

2. General description

The cyclo-filters type CACF-A are units used for the separation of dust from processed air.

Standard surface treatment in enamelling and powder enamelling for outdoor execution.

Only ATEX-Zone XX-marked unit may be used in explosion dangerous environments.

3. Functioning

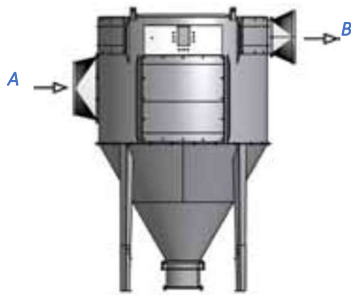

Processed air is led in through the side in the lowest connection, where after the air passes in the pre-separator and filter elements. Air leaves unit on the other side in upper connection.

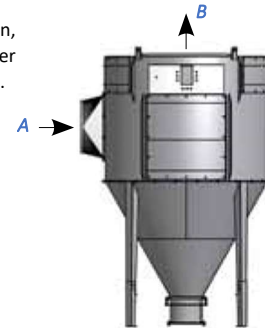

Filtered material is collected in an emptyable dust container.

3.1. Daily maintenance

Differential pressure (display) or watch is monitored daily. The pressure may not exceed 2,300 Pa. However, with filter elements G115A and G116A, this may be increased up to 3,000 Pa.

Dust container is emptied according to need, but may never be filled more than max. 75% of its volume.

At work with dangerous dust a plastic bag is placed in the dust container. The surplus plastic bag is turned over the dust container. When the bag must be removed, it is straightened out in its full length and is closed with 1 plastic strip, before it is taken out of the dust container to be destroyed according to governmental demands. Sack must always be mounted, when a relief hose is mounted.

Photo 1

ATTENTION:

Make sure the perforations are not obstructed!



Photo 2



Photo 3



Repairs may only be carried

out by professional trained personnel. Jet valves must be kept clean of dust.

4. Unit condition during operation

All filter doors must be closed and secured.

The dust container must be mounted and locked correctly during all steps of filter operation.

5. Intentional / unintentional application

Cyclone filter type CACF-A / CACF-T-A / CACF-V-A may not be used for the extraction of burning or glowing substances, like e.g. cigarettes, matches. Larger metallic chips or chips, paper, cleaning wipes etc. Unit may not be used for larger chips and the like. For this a cyclone type CY is used as a coarse separator.

In ATEX-zones only units may be used that are marked for the same zone. Filter units cannot be converted to another zone.

Repairs may only be performed with original spare parts.

5.1. Max. top load for cyclone filter type CACF-T-A:

Top connection load with flange on cyclone filter type CACF-T-A:

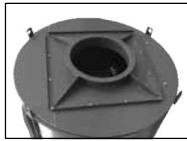

Type	Max. load
CACF-T-A 39, 52H, 78H	200 kg
CACF-T-A 52, 104H, 130H	300 kg
CACF-T-A 182H, 234H	400 kg

6. Mounting

CACF-A/CACF-T-A/CACF-V-A 39 - CACF-A/CACF-T-A/CACF-V-A 234 H:

Cyclone filter type CACF-A/CACF-T-A/CACF-V-A 38 - CACF-A/CACF-T-A/CACF-V-A 234 H are received lying on a pallet completely mounted with loose inlet.

Cyclone filter type CACF-A/CACF-T-A/CACF-V-A 182 H and CACF-A/CACF-T-A/CACF-V-A 234 H are further delivered with loose dust container and leg extensions.

CACF-A 260 DH - CACF-A 480 DH:

Cyclone filter type CACF-A/CACF-T-A 260 DH - CACF-A/CACF-T-A 480 DH are delivered on two pallets.

Cyclone filter type CACF-A/CACF-T-A 364 DH and CACF-A/CACF-T-A 468 DH are further delivered with loose dust container and leg extensions.

Cyclone filter type CACF-A/CACF-T-A/CACF-V-A is bolted to the pallet. When cyclone filter type CACF-A/CACF-T-A/CACF-V-A must be mounted, transport fittings are removed.

Cyclone filter type CACF-A/CACF-T-A/CACF-V-A is raised by crane lifting points in the top. D models are placed so the connection pieces are next to each other, where after inlet and outlet connections are mounted.

Cyclone filter type CACF-A/CACF-T-A/CACF-V-A must be bolted to an even, horizontal and stabile surface.

6.1. Filter placement

At cyclone filter placement the environment and fire demands must be considered. At EX- unit mounting the danger zones must be taken into consideration

Note : Zone range 5 is intended as a guide, normal radius of 1000 mm around the outlet.

Zone range 6 depends on the dust type and the concentration of it.

ATEX-zones internally in unit during operation according to EN60079-10-2:2013:

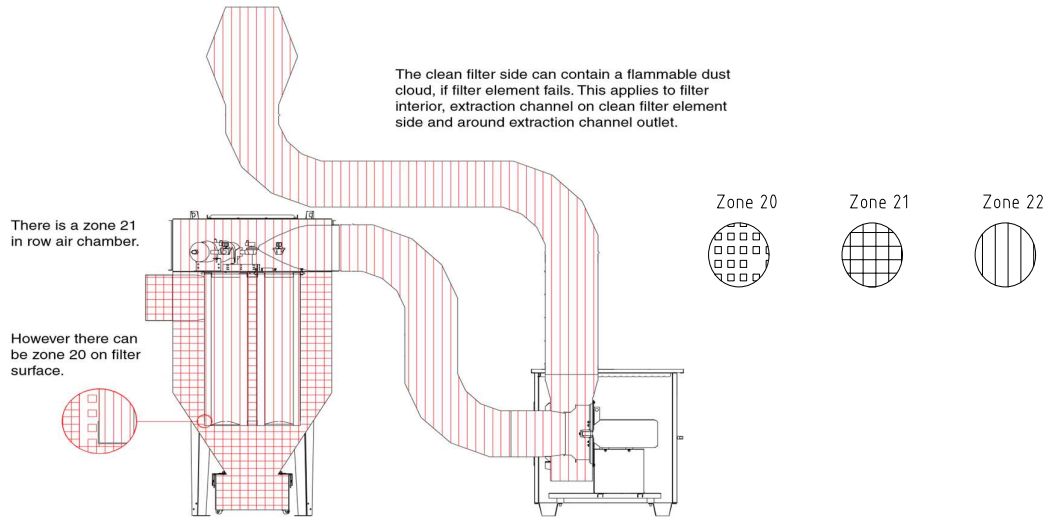

ATEX-zones at outlet during operation according to EN60079-10-2:2013:

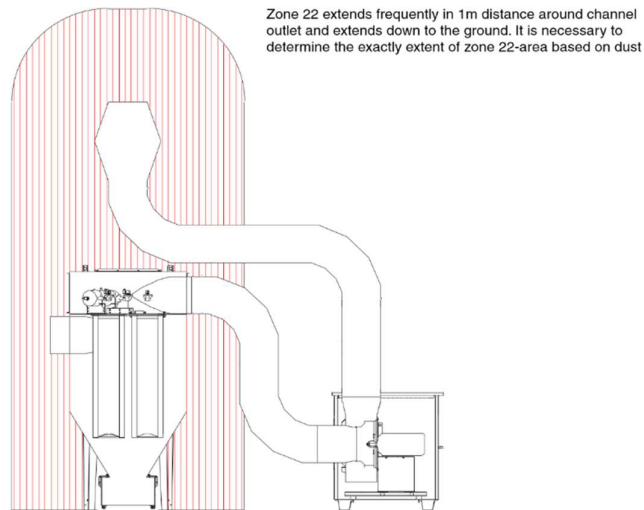

ATEX-zones at container emptying outside operation according to EN60079-10-2:2013:

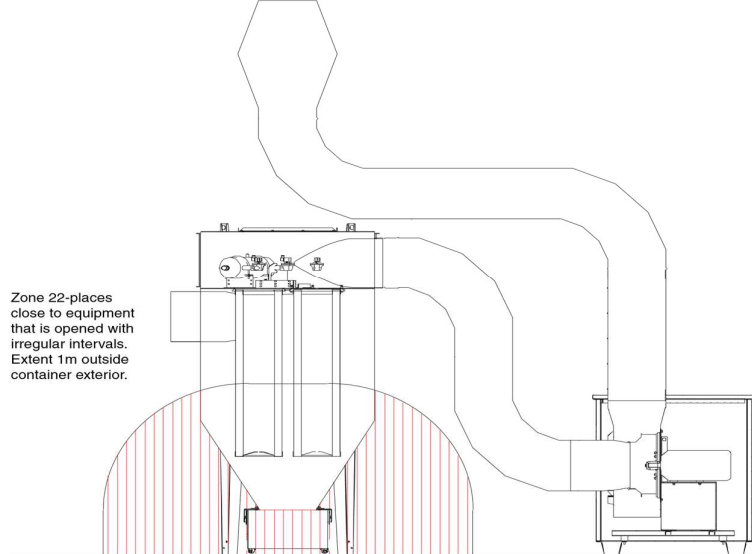

ATEX-zones at container emptying outside operation according to EN60079-102:2013 (only for CACF-T-A versions):

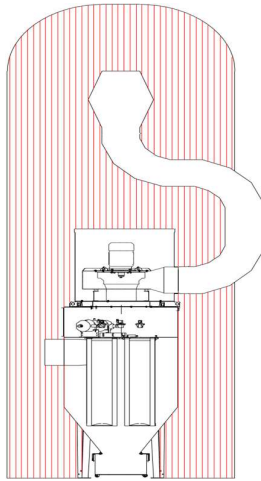

Zone 22 extends frequently in 1m distance around channel outlet and extends down to the ground. It is necessary to determine the exactly extent of zone 22 area based on dust and process characteristics.

6.2. Electrical connections

Electrical connection for differential pressure control type ECOMATIC-S are made in the control box, which is connected to 230 V, 50 Hz and earth.

DO NOT FORGET to close the control box firmly after mounting. Humidity can destroy the print.

Connection must be in accordance with the Power Code and must be breakable from supply.

Electrical connection must be active for so long after operation with ECOMATIC-S -control as the after-cleaning takes. The control box diagram is enclosed.

For ATEX-units the special rules in the Power Code must be followed. And for ATEX-units all parts must be securely earthed. Where there is a dust container, this must also be earthed.

6.3. Compressed air connection

The compressed air connection must give min. 5.5 - max. 6.0 bar dry compressed air. The connection is made at the end of the header tank. A reduction valve and water separator (½”) can be advantageous.

DO NOT FORGET compressed air at possible after-cleaning.

6.4. Ducting connection

The ducting connection must be made with approved ventilation pipes.

The ducting connection for D-models must be made in such a way that the dust is equally spread in the two units, e.g. vertically falling with 1 piece 90°-bend, or by sufficient long horizontal ducting.

For ATEX-units, it must be secured that piping cannot be blown away at a possible explosion.

6.5. Rotary valve (optional)

The rotary valve must be securely mounted on the unit and it must be airtight. It must be in operation at the start and during the running of the filter unit.

At rotary valve chamber mounting EN ISO 13857 must be observed.

6.6. Adjustments

Every filter unit is dimensioned for a certain workload which may not be exceeded as it would result in an improper function of the unit or a premature lifespan.

The unit is dimensioned following the following criteria's :

_____ Maximum air volume

_____ Type of dusts

Type of fan :

Type of cartridges : xx cartridges G1 xx

Total surface area: xx m²

6.7. Differential pressure control

Filter element cleaning takes place by differential pressure control type ECOMATIC-S, which is programmed at the factory.

Control is automatically operational upon receipt. Display shows first differential pressure when it is at minimum 200 Pa.

6.8. Alarm on EN 15012-1 units

When a differential pressure is created over the filter elements that is larger than allowable, a yellow flashing light (ø57mm) on the control box will light up.

If an alarm is requested at the affected work places, yellow flashing lights can be connected parallel with the mounted light.

7. Noise damping

Average noise level excluding cleaning shot cycles : more or less 75 dB (A).

Average noise level including cleaning shot cycles : more or less 85 dB (A), this can be brought down to 75 dB (A) if an acoustic booth is placed on the header tank.

8. Maintenance

Filter unit must be maintained 1 to 2 times a year to work optimally.

Differential pressure settings are checked (see instructions for differential pressure control type ECOMATIC-S in the back of these instructions). Differential pressure may not exceed 2,300 Pa (3,000 Pa with filter material G115A and G116A) at max. set operation point for air volume.

Check that all valves shoot correctly. If the valves are checked with open clean air chamber, you must use ear defenders for 95-110 dB(A) (SNR=35).

With electrical supply removed check the tightness of pipe connections, tank and valves. Tank is emptied for water through connection.

When compressed air is disconnected, check clean air chamber for possible dust.

If dust occurs, check filter sealing and filter elements for tightness between elements. Sealing at doors and dust container are checked for damages - possible defects are corrected, or if necessary seals are replaced.

At filter defects, tight filters that cannot be washed (G105 and G104A), or worn-out filters must be replaced. Use protective clothing, gloves, and respirator with filter adjusted according to work place dust type.

Filter cartridge durability is variable, depending on circumstances such as filter stress, dust type and volume. Filter cartridges get blocked with time due to very fine particles that attach themselves to the fibers.

Also be aware whether compressed air operates with defect pressure reducing valve with water separator. This means an internal dirtying of filter cartridges. Under normal circumstances there will be a certain dust layer on the outside of cartridge, even after compressed air cleaning.

This layer increases the filtration capacity and the differential pressure.

If noticeable capacity reduction occurs, we recommend cartridge cleaning with high pressure cleaner (see point 8.2).

Every filter cartridge is mounted with bayonet grip attached with 3 bolts in filter mounting plate.

8.1. Cartridge replacement

Every electric supply must be disconnected as well as pressure tank emptied for air before filter replacement from clean air side.

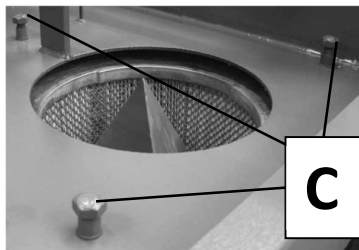

Side doors to clean air and row air chambers are dismounted. All filter bolts in clean air chamber are screwed completely down (point C, page 8).

Bolts for filter cones are removed (point D, page 8). Now the filter cartridges can be removed.

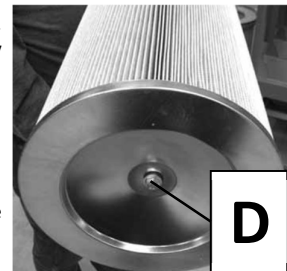



This is done by guiding a plastic bag up around the filter cartridge from beneath (Point E, page 8), gripping the cartridge and turning it clockwise until it is released from the bolts.

E

Filter cartridges are removed from the filter units, filter cone is removed, and plastic bag is closed with 1 plastic strip (point F, page 8).



F

The new filter cartridges (check sealing) are hung on the filter bolts. They are fastened hereafter (point G, page 8). Doors are mounted.

Certificated units W2 and W3 must use plastic bag and strips at filter change. Used filter elements must be disposed of according to governmental demands.

8.2. Cartridge cleaning

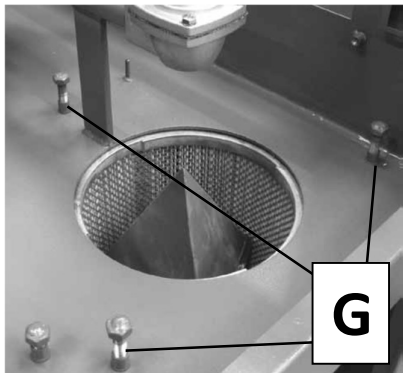

The filter cartridge type G103 can be cleaned, after having been dismantled from the filter as described in the procedure point 8.1. These can be cleaned with a high pressure cleaner with a maximum temperature of 50°C. Soap WITHOUT detergent can be used if needed.

The filter cartridges G104 and G105 **CANNOT** be cleaned.

Place the cleaner nozzle at a distance of 30 to 50 cm from the cartridge (on WIDE spread). Only clean the outside of the cartridge.

The cartridges must be completely dry before reinserting them in the filter unit.

New filter elements must in dimension be equal to original cartridge. Filter cloth quality must be according to filter job. Original type of filter elements can be seen on machine marking.

G

8.3. Jet valve exchange / repair

Exchange may only take place, when supply and compressed air are not connected to unit, and compressed air tank is emptied by compressed air connection.

Coil, membrane and valve top are exchangeable by disconnecting electric plug, where after 4 pcs. M6-bolts are loosened and new coil and membrane are mounted.

9. After maintenance

After the maintenance operations are completed, make sure that all electrical and pneumatic connections are established.

Test and control the filter unit before operation.

10. Differential pressure control - type ECOMATIC-S

10.1. General description



Economisers in the ECOMATIC-S range are digital sequential timers with built-in differential pressure switches.

The versions ECOMATIC-S4, ECOMATIC-S6, ECOMATIC-S12, ECOMATIC-S20 and ECOMATIC-S32 enable control of up to 4, 6, 12, 20, and 32 solenoid valves respectively. The version ECOMATIC-S64 is equipped with an expansion card with 32 outputs, expanding control capacity to up to 64 solenoid valves. In the same way, the model ECOMATIC-S96 is equipped with 2 expansion cards for capacity expansion up to 96 solenoid valves.

In all versions there is a display with 3 digit that can display the differential pressure unit of programmed (tens Pa, mmH₂O, mbar, kPa and mmHg) or the number of the cleaning valve; the three keys also enable programming of parameters on the instrument according to personal requirements including, pause time, operation time, post-cleaning time (or number of cycles) and washing start and end pressure, postcleaning pressure, alarm pressure and operation mode (automatic/manual).

All models are equipped with LEDs to display activation of outputs, pause phases and power on, the power supply presence, the post-cleaning status, and so on and so on.

The controllers with AC power supply are able to control both electronic valves with AC input and electronic valves with 24VDC. The output stage is made up of triac with on/off to zero-crossing to reduce noise.

Each model is supplied in polycarbonate enclosures with transparent lids and IP56 protection rating.

On demand, the ECOMATIC-S instruments can be provided of an ACTIVE analogical output proportional to the pressure read by the sensor. The pressure interval allowed is programmable through two parameters: "P14" e "P15".

10.2. General features

Voltage:	24 Vac, 115 Vac, 230 Vac +/- 15%, 50-60Hz.
Fuses ECO-S 4/6, 12:	F2 general fuse 2A 5x20 rapid F4 electro-valves power supply fuse 1.6A 5x20 delayed
Fuses ECO-S 20/32/64/96:	F1 general fuse 2A 5x20 rapid F2 electro-valves power supply fuse 1.6A 5x20 delayed
Working temperature:	-10 / +50 °C;
Connection:	Through screw terminals boards
Max Adsorbed Power:	50VA.
Input ECOMATIC -S 4/6/12/20/32/64/96:	n° 1 inputs opto-isolated
Relay Output ECOMATIC -S 4/6/12/20/32/64/96:	n° 1 relay 2A resistant load 115Vac
Relay Output ECOMATIC -S 20/32/64/96:	n° 4 relay 2A resistant load 115Vac
Electro-valves Output:	outputs triac with activation/deactivation <i>zero-crossing</i> 24, 115 o 230 Vac and 24Vdc with max. current 2A.

10.3. Technical features timer

Standard Pause Times:	Duration: 1- 999 sec	Precision: 0,1 sec
Standard Working Times:	Duration: 0.03 - 9.99 sec	Precision: 0,01 sec
Post Cleaning Times:	Duration: 1 - 999 sec	Precision: 0,1 sec

10.4. Technical features Active Analog Output (optional)

10.4.1. CURRENT OUTPUT

Visualization range : From 4.0 to +20.0 mA (standard) / From 0.0 to +20.0 mA (optional)
Precision : +/- 0.1 mA, +/- 1 digit.
Maximum load allowed : 500 Ohm

10.4.2. VOLTAGE OUTPUT

Visualization range : From 0.0 to +5.0 V (optional) / From 0.0 to +10.0 V (optional)
Precision : +/- 0.1 V, +/- 1 digit.
Minimum load allowed : 1K Ohm

Terminals 5,6,7: in case of terminals for expansion board 4-20mA;

- Terminal 5: positive terminal for analogical output board;
- Terminal 6: negative terminal for analogical output board;
- Terminal 7: connection frame analogical cable (optional, but advised);

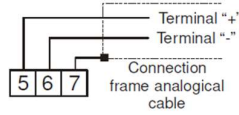

Note: the analogical output is an ACTIVE type.

- 7 - Display 7 Segments 3 DIGIT;
- 8 - Enter Key (E)
- 9 - Decrease Key (↓)
- 10 - Increase Key (↑)
- 11 - Common terminal by free contact for electro-valves
- 12 - Common terminal with + 24Vdc for 24Vdc electro-valves

10.6.2. LAYOUT ECOMATIC12- S

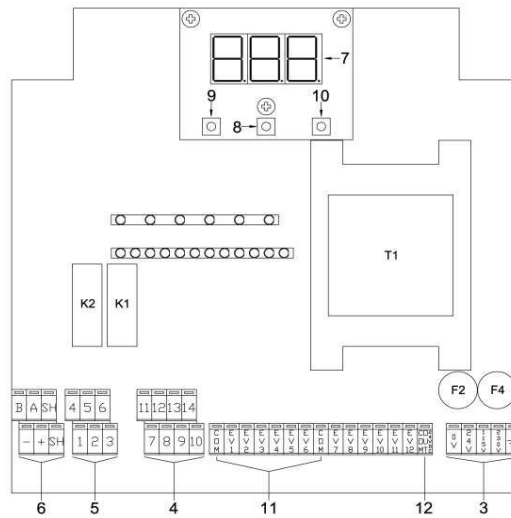

1. - F2, Power supply protection fuse
2. - F4, Electro-valves protection fuse
3. - Power supply terminals
4. - Input Contacts terminals

Terminals 7, 8: Post-cleaning input;

Input open: no-activated post-cleaning;

Input close: activated post-cleaning;

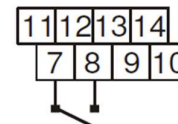

5. - Relay output terminals:

Terminals 4,5,6: Relay Contact 1;

Terminal 4: Contact N.C.

Terminal 5: Common.

Terminal 6: Contact N.O.

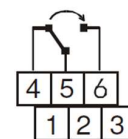

6. - Auxiliary outputs terminals (optional, used with expansion boards):

Terminals -, +, SH: Terminals for expansion board analogical output;

Terminal -: negative terminal for analogical output board ;

Terminal +: positive terminal for analogical output board;

Earth Terminal: connection frame analogical cable (optional, but advised);

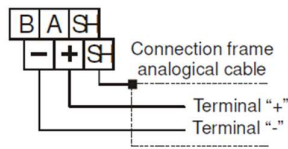

Note: the analogical output is an ACTIVE type.

- 7. - Display 7 Segments 3 DIGIT;
- 8. - Enter Key (E)
- 9. - Decrease Key (↓)
- 10. - Increase Key (↑)
- 11. - Common terminal by free contact for electro-valves
- 12. - Common terminal with + 24Vdc for 24Vdc electro-valves

10.6.3. LAYOUT ECOMATIC-S 20/32/64/96

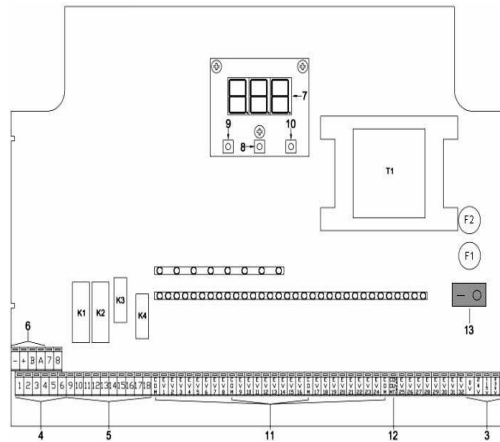

- 1 - F1, Power supply protection fuse.
- 2 - F2, Electro-valves protection fuse.
- 3 - Power supply terminals
- 4 - Input Contacts terminals:

Terminals 1, 2: Post-cleaning input

Input open: no-activated post-cleaning
 Input close: activated post-cleaning

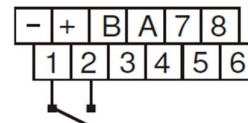

- 5 - Relay output terminals:

Terminals 9,10,11: Relay contact 1 (K1)

Terminals 9: Contact N.C.
 Terminals 10: Common
 Terminals 11: Contact N.O.

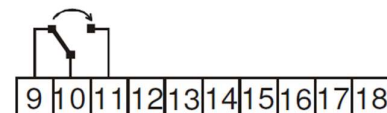

- 6 - Auxiliary outputs terminals (optional, used with expansion boards):

Terminals -, +, SH: Terminals for expansion board analogical output

Terminal - : negative terminal for analogical output board

Terminal + : positive terminal for analogical output board

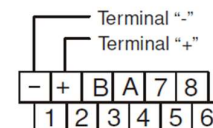

Note: the analogical output is an ACTIVE type.

- 7 - Display 7 Segments 3 DIGIT
- 8 - Enter Key (E)
- 9 - Decrease Key (↓)
- 10 - Increase Key (↑)
- 11 - Common terminal by free contact for electro-valves
- 12 - Common terminal with + 24Vdc for 24Vdc electro-valves
- 13 - On/Off Power Switch

10.7. Layout – Legend Delta-P Board ECOMATIC-S

In this device, you can choose the preferred measurement's unit through a P5 programmable parameter. Below are listed the maximum fields of reading pressure:

Measurement unit: Measurement range:	dPa from -99 to +999
Measurement unit: Measurement range:	mmH ₂ O from -99 to +999
Measurement unit: Measurement range:	mbar from -9.9 to +99.9
Measurement unit: Measurement range:	Kpa From -0.99 to +9.99
Measurement unit: Measurement range:	mmHg from -7.5 to +75.0
Precision:	+/- 1% F.S. , +/- 1 digit. Reference unit mmH ₂ O
Broken pressure:	0,5 bar (5000 mmH ₂ O).

10.7.1. Conversion Chart per Measurement units of pressure.

Equal to	mmH ₂ O	pascal	mbar	kpascal	mmHg
mmH ₂ O	1	9.8064	0.098064	0.0098064	0.07355592
pascal	0.101974	1	0.01	0.001	0.007500617
mbar	10.1974	100	1	0.1	0.7500617
kpascal	101.974	1000	10	1	7.500617
mmHg	13.5951	133.3224	1.333224	0.1333224	1

The temperature range of inlet gas to the pressure sensor is -40 ° C to +125 ° C. For values above or below it is necessary to provide cooling or heating gas.

10.8. ECOMATIC-S Power Supply

All the ECOMATIC-S models can have as power supply 3 different tensions 24 Vac, 115 Vac e 230 Vac.



CAUTION
Ensure that the power supply is disconnected before making or modifying cable connections.



The power supply has to be connected in this way (according to the chosen power supply).

10.8.1. ECOMATIC-S 4/6/12/20/32/64/96

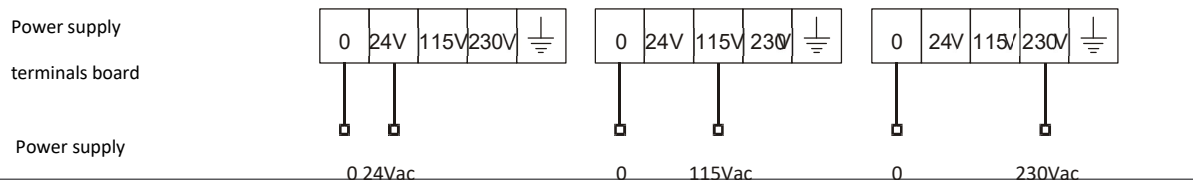

Note

- The power supply has to be sectioned *upstream* of the equipment.
- Both for the *economizers* and the *electro-valves* has to be done the earth connection.
- You have to use shielded cable, far from noise sources, like Inverter power cables and engines in general.

10.9. Electro-valves Connection Scheme

The solenoid valves are connected between output terminals 1 -2 ... - N and terminal C (common) which is connected to a suitable power supply via an external connection.

The controllers are equipped with more than one common terminal: obviously they are all interconnected and therefore do not require additional external connections.

According to the power supply given to the unit it is possible to use some types of electro valves. Here following the options:

- **Power supply 24 Vac:** it can be used **24 Vac** or **24 Vdc** electronic valves
- **Power supply 115 Vac:** it can be used **24 Vac**, **115 Vac** or **24Vdc** electronic valves
- **Power supply 230 Vac:** it can be used **24 Vac**, **115 Vac**, **230 Vac** or **24 Vdc** electronic valves

In case of controller's power supply with DC it is necessary to indicate it at the purchase order phase in order to adapt the circuit at this kind of output.

For the load's connection has to be done an external bridge connected according to the voltage of used electronic valves (to do the connection between the terminal C (common), and the power supply terminal, corresponding to the operating power of the electro valves). If you forget to do this connection, the electro valves will not be driven: the instrument will quickly scan all the outputs (the LEDs on the outputs will be switched on for a short time, and the pause LEDs will quickly blink) without activating any electro-valve.

N.B. : In the case of electro valves with 24DC, the connection bridge for the power supply of the load has to be done with ComOut 24VDC (output common with 24Vdc) and the terminal C (Common). This voltage is automatically created by the card and therefore it must not be supplied from outside.

The following pictures show the different kinds of connection that have to be made according to the working voltage of the electro-valves.

VOLTAGE SUPPLY VALVES VAC

ECOMATIC-NET 4/6

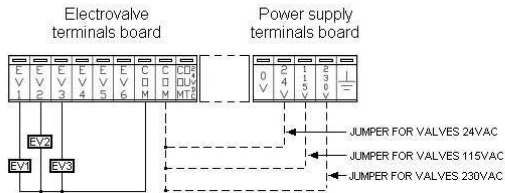

VOLTAGE SUPPLY VALVES VDC

ECOMATIC-NET 4/6

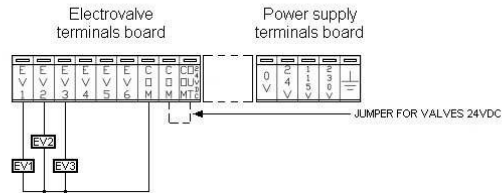

ECOMATIC-NET 12

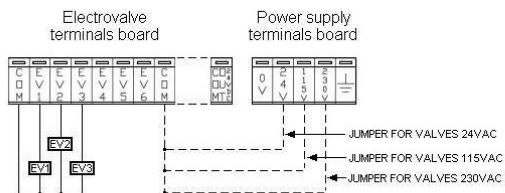

ECOMATIC-NET 12

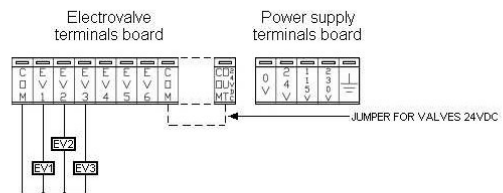

ECOMATIC-NET 20/32/64/96

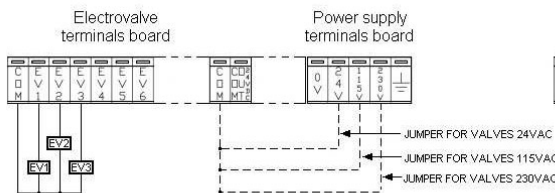

ECOMATIC-NET 20/32/64/96

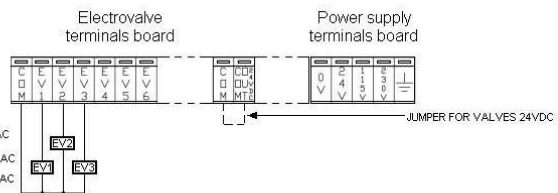

Control of electro-valves in parallel on a single output or multiple shot on more than one output.

ECOMATIC-S cards are able to control up to 2 Electro-valves for a single output, or to activate up to 4 outputs at the same time for 110V/220V power supply and 2 outputs at the same time for 24VAC/DC power supply.

ATTENTION: to activate more than one electro-valve in parallel or on various outputs, you need to have *the same* tension for valves power supply and instrument power supply. In this way, the requested power is supplied by the supply net (e.i. instrument power supply 230VAC and coils 230VAC).

CAUTION

!In all the models of ECOMATIC-S, in the case you have to drive two electro-valves at the same time, the value of two fuses on the board has to be changed:

- the one for general protection of 2A quick has to be changed into 4A quick and the one for load protection of 1.6A delayed has to be changed into 3.15A delayed.

In particular, in the versions ECOMATIC-S 64/96, the connection of the double electro-valves to the outputs on the expansions has to be done according to the following scheme:

1st expansion (both ECOMATIC-S64 and ECOMATIC-S96)

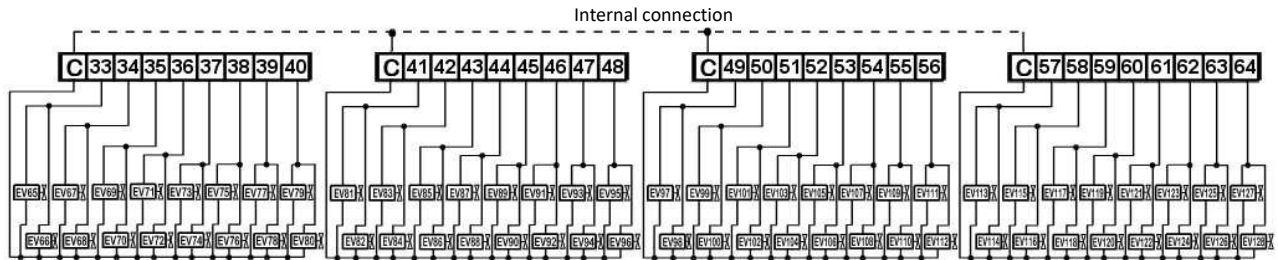

2nd expansion (just in the ECOMATIC-S96)

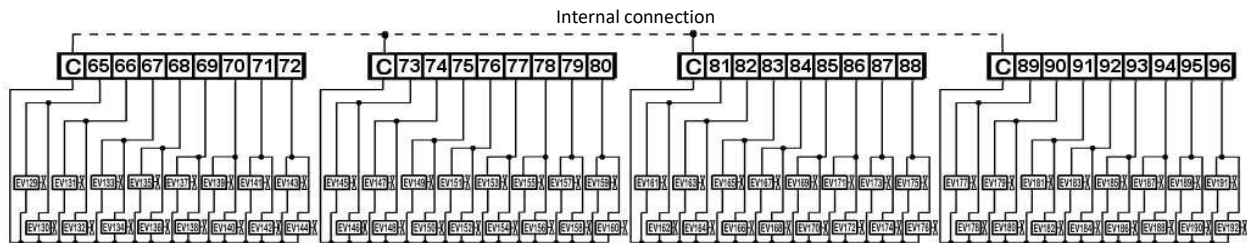

Note: For connecting the load of the double electro-valves on the *expansions* (ECOMATIC-S 64/96) it is necessary to do one *connection* between the terminal C (common) of the expansion board and the terminal C of the ECOMATIC-S32 board.

We suggest you to put the cables of electro-valves far from noise sources, like inverter power cables and engines in general;

10.10. Display visualization

Through the display you can see different information of the system, regarding pressure, output number or cleaning command, cycle status and value of analogical output. There are 2 or 3 visualization menu (3 if the analogical output is enabled) selected through the button **Inc** (↑) while the button **Dec** (↓) indicates which menu is visualizing. The three menus are divided as follows:

The 1° menu identifies the pressure value read by the instrument;

- visualization : **"Pr."**
- followed by a number to identify the pressure measure unit. : **"0"** tens Pascal
- "1"** mmH₂O
- "2"** mbar
- "3"** KPa
- "4"** mmHg

The 2° menu identifies the system status, the output number or cleaning command, and the command for cell opening or closing;

- if the system is in **STOP** or almost in stop, you will see: **"S.xx"**
- if the system is in **CLEANING**, you will see: **"U.xx"**
- if the system is in **POSTCLEANING**, you will see: **"P.xx"**

In all these statuses of the system, on the part xx you can view the following wordings:

- **number n°** (if it is an output for cleaning valve)
- **SC** (during the cycle start-up)

The 3° menu (if enabled) identifies the value of the analogical output

- visualization: **"Cor."** (if the output is in current)
- visualization: **"Vol."** (if the output is in tension)

10.11. Error visualization

10.11.1. Pressure error

When the instrument visualizes the pressure value, two indications of out of range are foreseen: if the input differential pressure is higher than the positive full scale set, the display will visualize the indication 'EEE'.

In the case the pressure would be lower than the negative full-scale set, the display will visualize the indication '-EE'.

10.11.2. E2PROM Error

In the case we will have problems with the configuration of the E2prom, the instrument will visualize on the display the indication "--" to show the loss of programming and setting data.

Pressing the key Dec (↓) the normal function of the instrument will be reloaded as well as the default data, although it will be necessary to do once more the setting and programming phase by qualified people in the company.

10.12. Preliminary Procedures

At the ignition, the unit will be ready for the visualization of the differential pressure value read by the internal sensor.

With the button Inc (↑) or Dec (↓) you can look through the visualizations of the pressure, the number of valve in cleaning and of the value in analogical output (if enabled).

To enter in the programming menu is enough to press the key E: it will appear the first parameter L1.

N.B. Please pay attention to this menu because it is where the proper function of the board comes from.

Pressing continuously the key Inc or Dec, it will be possible to look at one by one all the parameters.

The exit from the programming menu is automatic after 10 seconds when you do not press any key during the parameters scrolling.

10.13. Programming Parameters

The following table shows all the available parameters, explaining the function and the admissible range of values.

Param.	Function	Possible values	Default values	Notes
L1	Hourcounter.	0 - 65534 hours		Hourcounter functioning
L2	Cyclecounter	0 - 65534 cycles		Cyclecounter functioning
P1	Pause time	1 – 999 seconds	20 (5-30)	Automatic and Manual functioning
P2	Working time	0.03 – 9.99 seconds	0.25	
P3	Value of time or cycles.	1 – 999 seconds 1 – 999 cycles	5	Postcleaning functioning
P4	Postcleaning function.	0=Disabled 1=Internal 2=External	1	
P5	Unit pressure measure	0 = tens Pa 1 = mmH ₂ O 2 = mbar 3 =Kpa 4 = mmHg	3	Unit pressure measure
P6	Postcleaning time or cycles selection.	0= Time 1= Cycles	1	Postcleaning functioning
P7	Man./Auto	0=Manual 1=Automatic	1	
P8	Start cleaning pressure	From 0 to F.S. positive	0.90	Automatic functioning
P9	End cleaning pressure.	From 0 to F.S. positive	0.40	Postcleaning functioning
P10	Internal postcleaning pressure threshold	Da 0 al F.S. positive	0.1	
P11	Relay 1 pressure threshold	From 0 to F.S. positive	G115AV = 2.30 G116A = 3.00	Relay Output functioning
P12	Enable precoating.	0=Disabled 1=Enabled	0	Precoating Functioning
P13	Precoating threshold	From 0 to F.S. positive	1.20	
P14	Value of pressure responding to the minimum value of the analog output	From 0 to F.S. positive		Analog output functioning
P15	Value of pressure responding to the maximum value of the analog output	From 0 to F.S. positive		
P16	Relay 1 functioning selection.	0 – 1	0	Relay Output functioning
P17	Function of relay 1.	0=Normal 1=Temporized 2=Hysteresis pressure	0	
P18	Value of relay 1 function.	From 1 to F.S. positive or from 1 – 999 seconds	1	
P19	Pause time in post-cleaning mode	1 – 999 seconds	3	Post-cleaning functioning
H0	Pressure zero	To be done by specialized staff <i>only if</i> the pressure with open air vents is appreciably different from zero		

10.14. ECOMATIC-S Function

ECOMATIC-S instruments have two possibility to clean the filters, to be set in parameter P7.

The filter cleaning mode are Manual or Automatic.

With the Automatic functioning you can have a real save in air consumption and on the life of bags and filters, because you operate only when necessary.

Let's see in details these single functioning modalities:

Manual: the ECOMATIC-S drives one by one the output correspondent to the connected valves, regardless any kind of programming. The driving of the outputs starts from the first electro-valve, going ahead with the second, the third and so on and so on, after which starts again from the first. The working time and pause time will alternate each other between the activation of one output and the other.

Automatic: the electro-valves will be activated if the visualized pressure is higher to the one set in the parameter P 8 (starting cleaning pressure); the activation itself will be interrupted as soon as the pressure will go down the value set in the parameter P 9 (end cleaning pressure).

When the pressure goes down the end cleaning pressure, the normal cycle of function will be stopped just if the ECOMATIC-S is on pause phase and after the last valve of the cycle.

10.15. Delta-P Tubes Connection Scheme

Disposal of pressure tube connection on the ECOMATIC-s device are as follows:

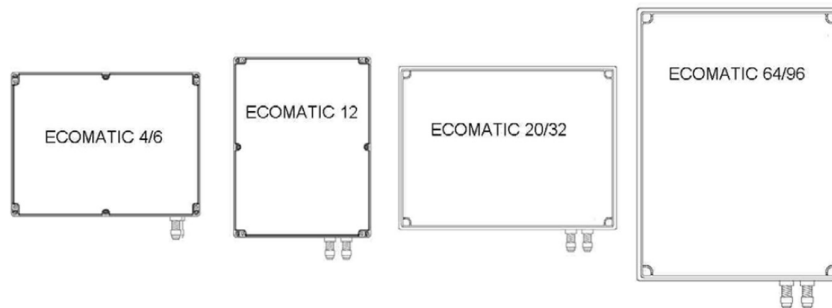

With the installation of pressure gauges is recommended the installation of filtered outlets to limit possible failure internal pressure sensor.

These filters prevent dust or other substances to be traced back to the pressure sensor and small bodies to obstruct the flow inside the tubes.

It can also be possible not to use these filters, but at the expense of the safety of the instrument.

These filters are mounted directly on the filter where they are usually positioned in the outlet pipes. It is recommended to install a filtered outlet for each pressure tube applied, both with the extent of Delta-P inside the filter:

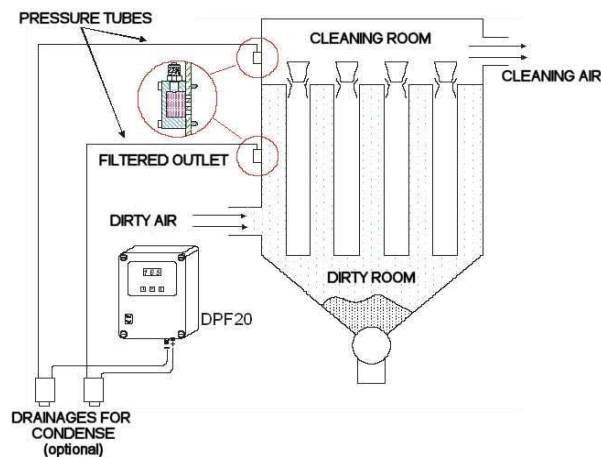

The pressure hose recommended is the Rilsan type 6x4.

The positive nozzle of the instrument must be connected to the dirty room while the negative nozzle must be connected to the clean room of the filter.

At temperatures above 125 ° C it is necessary to reduce the level of inlet sensor temperature in order to fall within the permissible temperature range (-40 °C / 125 °C). To do this we suggest using a length of copper tubing needed to dissipate excess heat.

Let's have a look now at the installation of these filters in details.

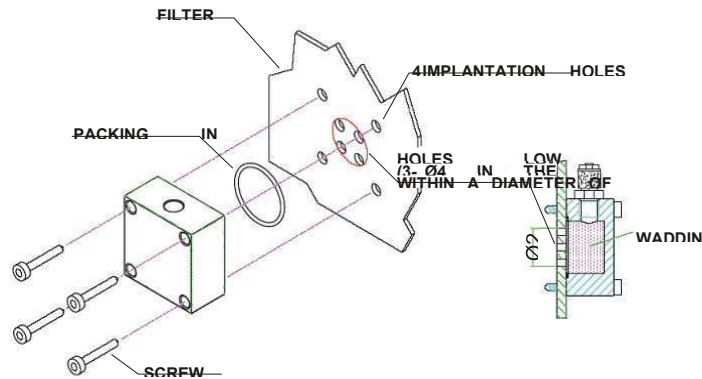

10.16. Pressure Zero Setting

During the operation it may happen that the pressure on the display slightly different for equal pressure applied to the sensor, due to the changing conditions of temperature, humidity, etc..

To restore the correct pressure, you must perform an operation to eliminate the pressure reading of the instrument.

Entering programming using the key E in the menu and make sure that the jets of grafting of the tubes are free, i.e. not connected to the pipes from the air filter.

Pressing Inc select the parameter H 0 and follow the steps listed below:

- Press **E** (flashes the message **0**); - Wait 4 or 5 sec.;
- Confirm the reset by pressing the **E** key (the display will show once more the indication **H 0**)
- Wait 10 seconds so that the display returns to the pressure value and verify that the reading is 0.



CAUTION

Pressure can be reset (parameter **H 0**) only if the pressure reading on display with outlets open is notably different from zero. This operation must be carried out exclusively by skilled personnel and only after the instrument has been switched on for at least 15 minutes.

10.16.1. Output test activation function

It is possible to use a particular configuration of the card to prove each exit in case it becomes necessary during the testing, maintenance or any mal operations.

To join this setup go with the key Dec (↓) on the number visualization of the active output. In this condition simultaneously press the keys Inc (↑) e Dec (↓) and so it enters the menu of test outputs. Once you will enter you will see the number of outputs by activating flashing.

To activate the visualized output press the key E, while to change the number of output use the keys Inc (↑) and Dec (↓). The minimum time that must pass for a shot through the following key E is 1 second. To return to the normal cycle of operation simultaneously press all three keys.

10.17. Active Analogical Output Functioning (optional)

ECOMATIC-S can provide a current or tension output, which changes in a linear way. When you place the order, you need to indicate the solution you need. Current or Tension output must be specified in order phase, as standard this option will be supplied with current output.

10.17.1. Current output

It is possible to generate a current which change in a linear way between 4-20 mA or between 0-20 mA in output, through the programming of P 14 e P 15 parameters.

P 14 parameter corresponds to the pressure which has to be supplied to obtain a current output equal to 4 mA or 0 mA. P 15 parameter corresponds to the pressure which has to be supplied to obtain a current output equal to 20 mA. According to the displayed pressure, it is possible to generate a current output linear function of the pressure.

N.B. : Max applicable load 500 ohm.

10.17.2. Tension output

It is possible to generate a tension which change in a linear way between 0-10V or 0-5V in output, through the programming of P 14 and P 15 parameters.

P 14 parameter corresponds to the pressure which has to be supplied to obtain a current equal to 0V. P 15 parameter corresponds to the pressure which has to be supplied to obtain a current equal to 5V or to 10V. On the basis of the displayed pressure, you can generate current output linear function of pressure.

NOTE: Minimum load applicable 1 Kohm.

10.17.3. Analogical output connection

Connection between ECOMATIC-S and expansion card 4-20 mA and a potential external has to be performed using the following terminals on the basis of the instrument model:

- for ECOMATIC-S 4/6, terminals n°5 (+), n°6 (-) and n°7 (earth) ;
- for ECOMATIC-S 12/20/32/64/96, terminals +, - and earth as indicated in the printed.

10.17.4. Hour-counter function

The value hour-counter is possible to be visualized in the parameter L 1 from the programming menu. The hours counter starts to count when the pressure visualized on the display is higher or equal to the one set in the parameter P 10 (post-cleaning pressure).

The maximum value that can be set for the number of hours is "65534", after which the counter is reset automatically.

Although the instrument is fitted with a 3-digit display, numbers comprising up to 5 digits can be displayed: for values from 0 to 999, the number of hours is displayed as normal; for values greater than 999, the display cannot show the entire number but when one of the 2 outer numbers (left or right) flashes, this indicates that the number on display is not complete. If the left number flashes, the remaining numbers for display are to the left and vice versa. If both numbers flash this means that there is a number remaining both to the left and right.

Example

If the number displayed is "954" and the number 9 is flashing, this means that there is a hidden number to the left of the number 9. Press "inc" to display the number to the left (the other numbers are shifted to the right). At this point, the number displayed is "395" but the whole number is "3954"; in this case the number 5 flashes to indicate a number remaining to the right. Press "Dec" to display the number to the right (the other numbers are shifted to the left, concealing the first figure to the left); the figure "954".

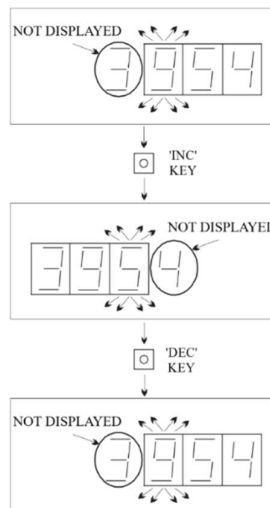

10.17.5. Cycle-counter function

Parameter L2 enables access and display of the counter monitoring operation cycles performed during output scanning.

The counting is done every time one complete cycle of activation of outputs even if these are not connected.

The total number of possible cycles is "65534", after which all stored values in the counter memory are reset.

The method to display the number of cycles is as described above for the hour counter.

10.18. Relay Output Functioning

The relays present on the ECOMATIC-S have different ways of functioning, selectable in the programming menu. Each relay is independent from the others, with its own parameters and with the possibility to activate every relay in a different way. The possible ways of functioning are:

1) = 0 as minimum relay:

- a) standard (see paragraph **STANDARD MINIMUM RELAY**);
- b) temporized relay (see paragraph **TEMPORIZED OUTPUT**);
- c) hysteresis (see paragraph **HYSTERESIS OUTPUT**);

2) = 1 as maximum relay:

- a) standard (see paragraph **STANDARD MAXIMUM RELAY**);
- b) temporized relay (see paragraph **TEMPORIZED OUTPUT**);
- c) hysteresis (see paragraph **HYSTERESIS OUTPUT**);

10.18.1. Relay of standard minimum and maximum

Let's suppose to work with relay 1 as minimum standard relay.

First of all, we need to set the value 0 in parameter P 16 and P 17, in P 11 the pressure value of relay work. When the pressure is equal or less than pressure in P 11, our relay will be activated.

Let's suppose to work with relay 1 as maximum standard relay.

First of all, we need to set the value 1 in the parameter P 16 and value 0 in the parameter P 17, in P 11 the pressure value of relay work. When the pressure is major than pressure in P 11, our relay will be activated.

10.18.2. Temporized output

The temporized output allows us to activate the relay with a settable pressure gap.

1) E.i.: relay 1 as minimum temporized relay.

First of all, we need to set the value 0 in P 16 parameter, in P 11 parameter the pressure value for relay, in P 17 the value 1 and in P 18 our time value.

Let's suppose P 11 equal to 20 mmH₂O and P 18 equal to 3 sec.

The functioning of our relay will be the following:

- the relay will be activated after 3 seconds when the pressure will be equal or less than 20 mmH₂O;
- the relay will be deactivated when the pressure will be more than 20 mmH₂O.

2) E.i.: relay 1 as maximum temporized relay.

First of all, we need to set the value 1 in P 16 parameter, in P 11 parameter the pressure value for relay, in P 17 the value 1 and in P 18 our time value.

Let's suppose P 11 equal to 20mmH₂O and P 18 equal to 5 sec.

The functioning of our relay will be the following:

- the relay will be activated after 5 seconds when the pressure will be more than 20 mmH₂O;
- the relay will be deactivated when the pressure will be equal or less than 20 mmH₂O.

10.18.3. Output with hysteresis

Output with hysteresis allows us to activate and deactivate the relay with a settable pressure gap.

1) E.i.: relay 1 as **minimum relay and pressure hysteresis**

First of all, we need to set the value 0 in parameter P 16, in P 11 parameter the pressure value for relay, in P 17 the value 2 and in P 18 our hysteresis pressure.

Let's set P 11 equal to 20 mmH₂O and P 18 equal to 4 mmH₂O.

The functioning of our relay will be the following:

- the relay will be activated when the pressure will be equal or less than $20-4=16$ mmH₂O;
- the relay will be deactivated when the pressure will be more than $20+4=24$ mmH₂O.

2) E.i.: relay 1 as **maximum relay and with pressure hysteresis**

First of all, we need to set the value 1 in P 16 parameter, in P 11 parameter the pressure value for relay, in P 17 the value 2 and in P 18 our hysteresis pressure.

Let's set P 11 equal to 20 mmH₂O and P 18 equal to 4 mmH₂O.

The functioning of our relay will be the same:

- the relay will be activated when the pressure will be more than $20+4=24$ mmH₂O;
- the relay will be deactivated when the pressure will be equal or less than $20-4=16$ mmH₂O

10.19. Post-Cleaning Functioning

Post-cleaning is activated through the closing of an external contact (if **P 4=2**), or when the pressure is *lower* than the value set in **P 10** parameter (se **P 4 =1**); the economizer scans in sequence all the outputs, alternating work time (**P 2**) to pause time (**P 19**). The process ends after a *time* (if **P 6=0**) or the *number of cycle* (if **P 6= 1**) set in **P 3** parameter.

The internal post-cleaning (**P 4 =1**) has effect in Automatic and not in the manual functioning.

The external post-cleaning (**P 4 =2**) has effects in all the functioning modalities.

The post-cleaning cycles begin to be counted starting from the first crossing of the electro-valve N°1 to consider complete scan cycles. If the post cleaning starts from valve N° 10 having 12 valves in total, the first cycle will be composed by 12 + 3 (10-11-12) valves.

Note: if **P 4 = 1**, the activation of the post-cleaning cycle can take place only if the device, after the ignition, has passed the threshold set in **P 10** at least one time.

10.20. Precoating Functioning

When the ECOMATIC-S is set to Automatic, the parameter **P 12 = 1** and the parameter **P 13** is set to a value higher than the start pressure cleaning or minimum pressure, the tool remains stationary (in stop) till the pressure on the display shall not exceed the pressure of pre-coating.

After passing this threshold, the cyclical starts and now it behaves normally, that is the function of pre-coating is automatically disables permanently (even power cycle the instrument, the disabled remain stored).

NOTE: To re-enable the function of pre-coating is necessary again to force the parameter **P 12 = 1**.



Contacts

Formula Air The Netherlands
 Head Office / Production / Sales
 Bosscheweg 36
 5741 SX Beek en Donk,
 The Netherlands
 +31 492 45 15 45
info-nl@formula-air.com

Formula Air Belgium
 Logistics / Sales
 Rue des Dizeaux 4
 1360 Perwez
 Belgium
 +32 81 23 45 71
info-be@formula-air.com

Formula Air Baltic
 Production / Sales
 P. Motiekaičio g. 3
 LT-77104 Šiauliai
 Lithuania
 +370 41 54 04 82
info-lt@formula-air.com

Formula Air France – West
 Sales
 6, avenue des Lions
 44800 Saint-Herblain
 France
 +33 9 72 15 29 38
contact-ouest@formula-air.com

Formula Air France – North
 Sales
 Zac de la Carrière Dorée
 BP 105, 59310 Orchies
 France
 +33 9 72 15 29 38
contact-fr@formula-air.com

Formula Air France – East
 Sales
 2, rue Armand Bloch
 25200 Montbéliard
 France
 +33 9 72 15 29 38
contact-est@formula-air.com

Formula Air France – South
 Sales
 Chemin de Peyrecave
 09600 Regat
 France
 +33 9 72 15 29 38
contact-sud@formula-air.com

Formula Air Germany
 Sales
 Dr.-Oetker Straße 10
 54516 Wittlich
 Germany
 +49 6571 269860
info-de@formula-air.com

Formula Air Vietnam
 Production / Sales
 #33, Lot 2, Den Lu 1
 Hoang Mai District, Hanoi
 Vietnam
 +84 (24) 38 62 68 01
info@vinaduct.com

Formula Air Nordic
 Sales
 Stortorget 17
 211 22 Malmö
 Sweden
 +46 40 654 06 10
info-scan@formula-air.com

Formula Air Export
 Sales
 Rue des Dizeaux 4
 1360 Perwez
 Belgium
 +32 81 23 45 71
info-be@formula-air.com