

# Technical appendix

General information

Technical information

Edge types

**General information**

**Selecting the edge type of the ducting element**

The proper edge in function with the ducting type and the application will ensure a sturdy and airtight assembly. In order to have the correct edge for your product, you will have to select one of the following :

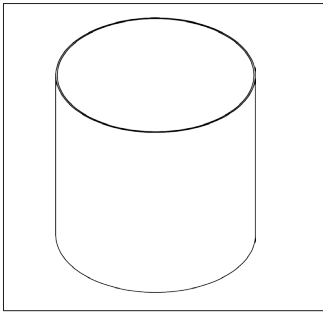

**gl edge on medium pressure ducting:**

A "gl" edge is a smooth straight pipe with no edge.

NOTE : the diameter on a gl medium pressure component is always measured on the inside of the product.

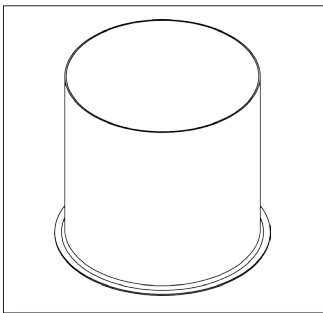
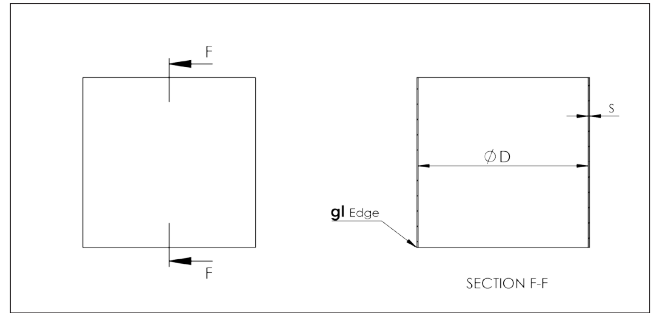

**fb edge :**

A "fb" edge is a 6 mm edge on standard ducting so that all kinds of rings can be fitted.

NOTE : not all rings will fit if the element is conical.

The edge can be slightly rounded or perfectly square at the fold depending on the folding method.

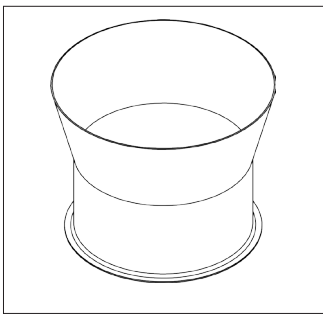
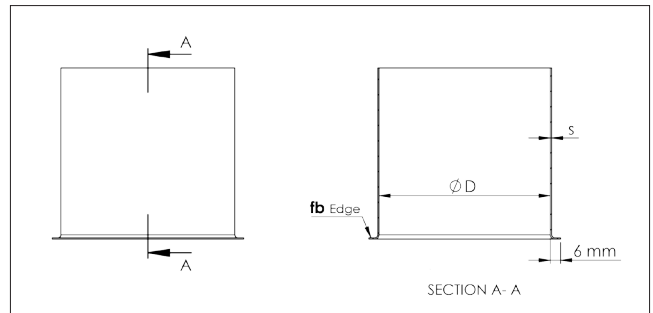

**fbf edge :**

A "fbf" edge is a 6 mm edge on standard conical ducting with an extension of 50 mm straight pipe so that all kinds of rings can be fitted.

The edge can be slightly rounded or perfectly square at the fold depending on the folding method.

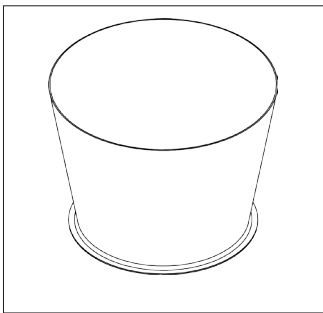
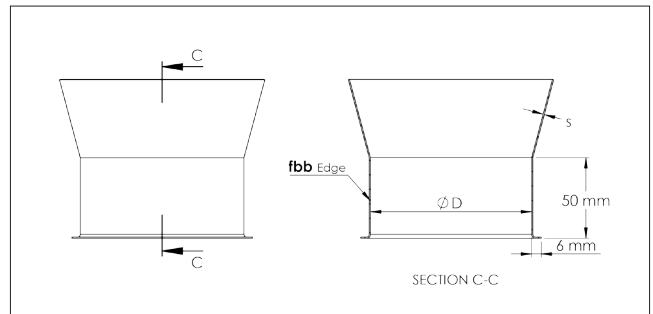

**fbe edge :**

A "fbe" edge is a 6 mm edge on standard conical ducting which has a slight incline so that all kinds of rings can be fitted.

NOTE : the maximal pipe angle is 1/10. Example : taper  $\phi 140/120$  has a difference of 20 mm and thus needs to be at least 200 mm long.

The edge can be slightly rounded or perfectly square at the fold depending

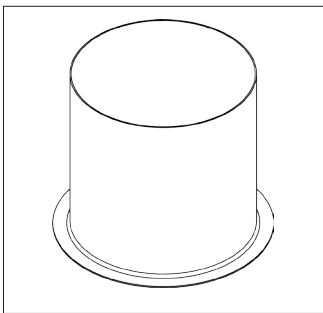
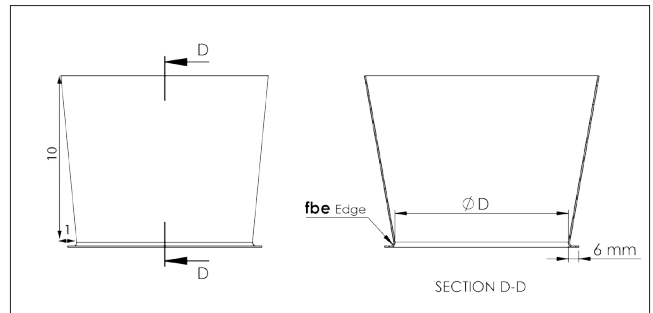

**fbf edge :**

A "fbf" edge is a 10 mm edge on standard ducting so that all kinds of flanges can be fitted.

The edge can be slightly rounded or perfectly square at the fold depending on the folding method although a square execution is preferable.

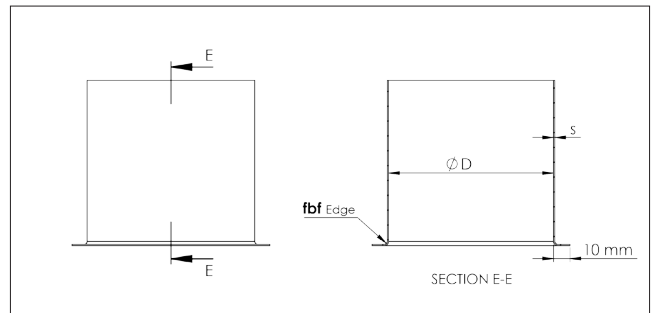

**General information**

**Selecting the edge type of the ducting element :**

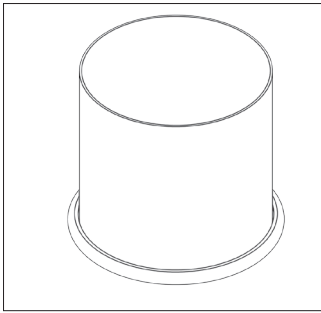

**rb edge :**

A "rb" edge is a rolled edge on standard ducting for a quick fit with rapid-lock rings. The rolled edge is in function of the ducting diameter and can be Ø6 (Ø80 to 160), Ø8 (Ø180 to 250) or Ø10 (Ø300 to 710).

NOTE : only specific rapid-lock rings for rolled edges fit on these edges.

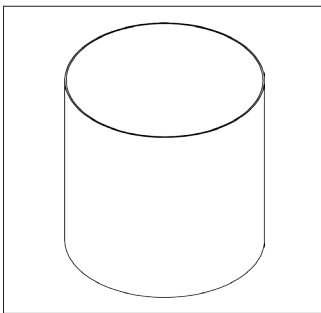
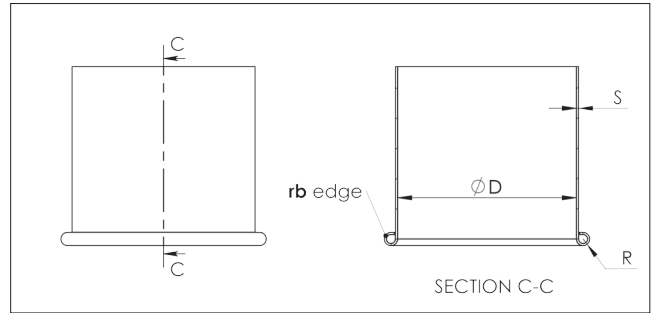

**gl edge on high pressure ducting:**

A "gl" edge is a smooth straight pipe with no edge.

NOTE : the diameter on a gl high pressure component is always measured on the outside of the product.

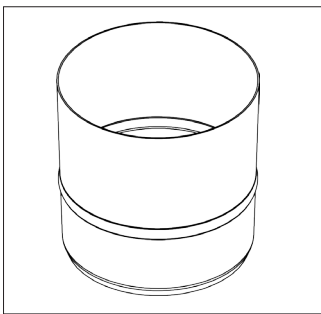
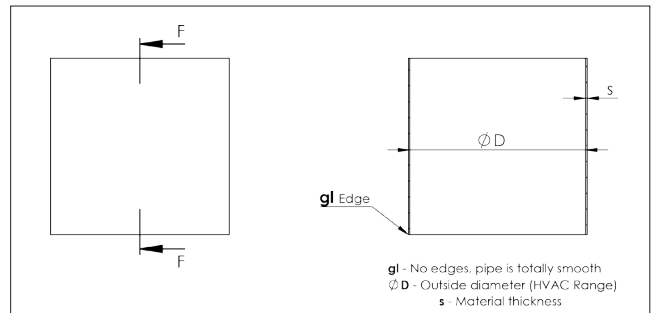

**fsl edge :**

A "fsl" edge is an edge especially design to fit flexible hoses over the ducting element.

The pipe diameter is slight smaller than the standard nominal pipe diameter and has a boom to properly maintain the flexible hose in place (the use of a hose ring is recommended).

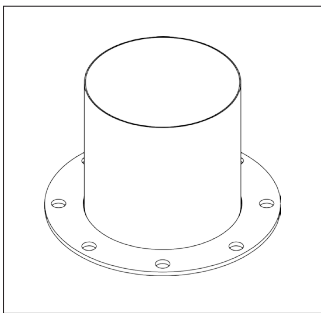
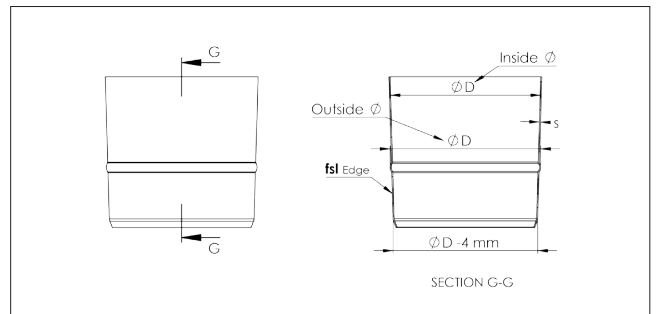

**L.fl edge :**

A "L.fl" edge is a 10 mm edge on standard ducting with a loose FORMULA AIR flange mounted on the component.

The edge can be slightly rounded or perfectly square at the fold depending on the folding method although a square execution is preferable.

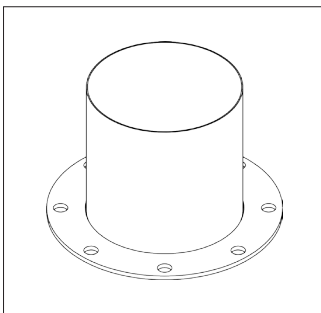
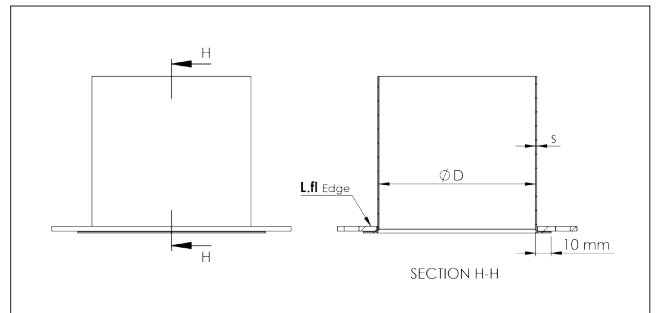

**L.cfl edge :**

A "L.cfl" edge is a 10 mm edge on standard ducting with a loose FORMULA AIR Stainless Steel flange mounted on the component. (AISI 304)

The edge can be slightly rounded or perfectly square at the fold depending on the folding method although a square execution is preferable.

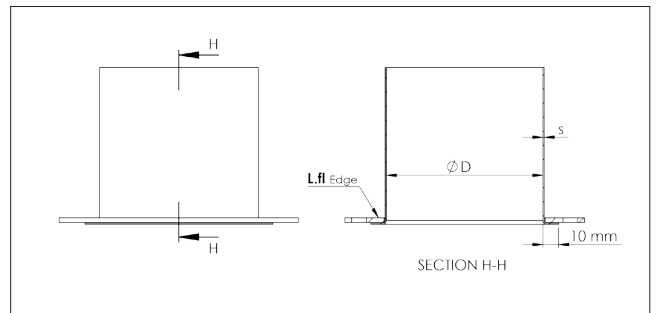

**General information**

**Selecting the edge type of the ducting element :**

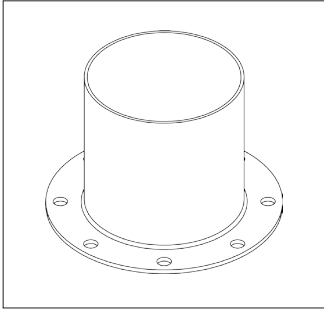

**W.fl edge :**  
A "W.fl" edge is a component with a fully welded FORMULA AIR flange along the edge.

The thickness of the flange is according to our flange standards.

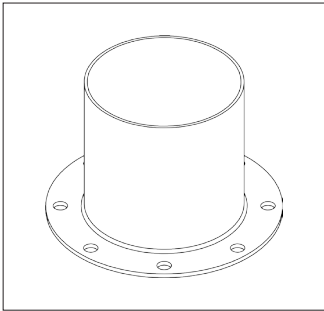
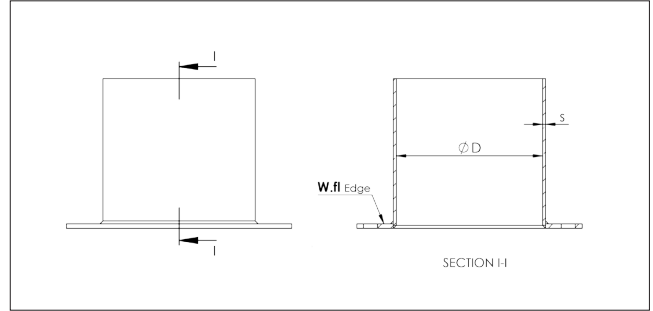

**W.cfl edge :**  
A "W.cfl" edge is a component with a fully welded FORMULA AIR Stainless Steel flange along the edge. (AISI 304)

The thickness of the flange is according to our flange standards.

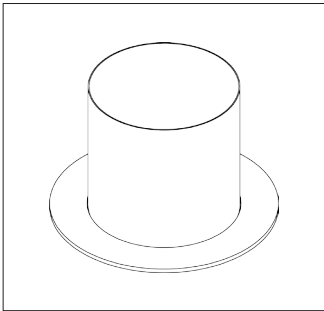
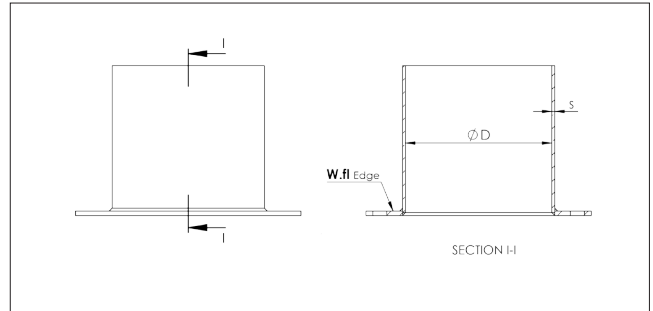

**U.fl edge :**  
A "U.fl" edge is a 10 mm edge on standard ducting with a loose undrilled flange mounted on the component.

The edge can be slightly rounded or perfectly square at the fold depending on the folding method although a square execution is preferable.

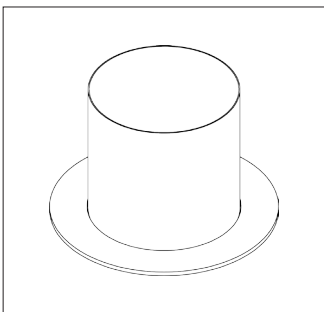
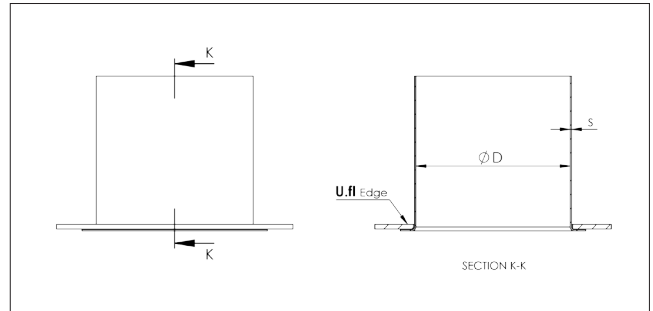

**U.cfl edge :**  
A "U.cfl" edge is a 10 mm edge on standard ducting with a loose undrilled Stainless Steel flange mounted on the component. (AISI 304)

The edge can be slightly rounded or perfectly square at the fold depending on the folding method although a square execution is preferable.

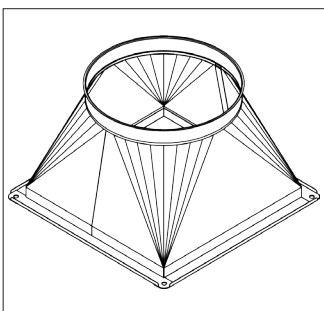
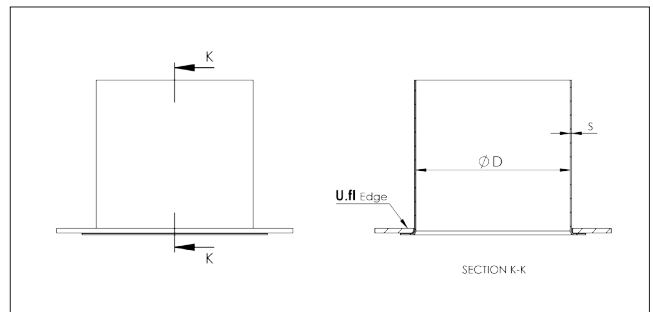

**D.fl edge :**  
A "D.fl" edge is an edge with an integrated flange made of the same material and plate thickness as the component.

It is usually used on light gauge rectangular flange connections with a customer specific hole pattern.

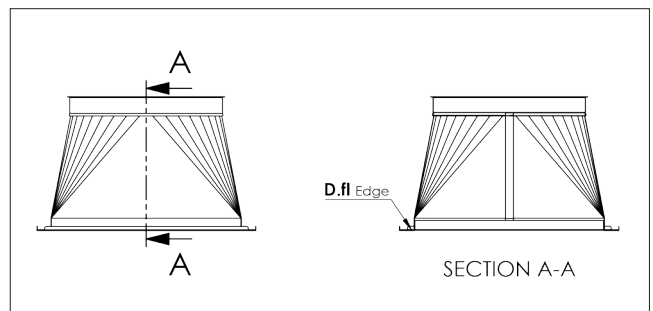

**General information**

**Selecting the edge type of the ducting element :**

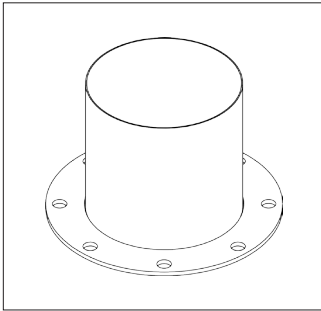

**L.t2fl, L.t3fl, L.t4fl edge :**

A "L.txfl" edge is a 10 mm edge on standard ducting with a loose DIN REIHE flange mounted on the component.

The edge can be slightly rounded or perfectly square at the fold depending on the folding method although a square execution is preferable.

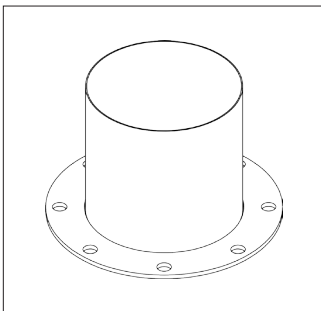
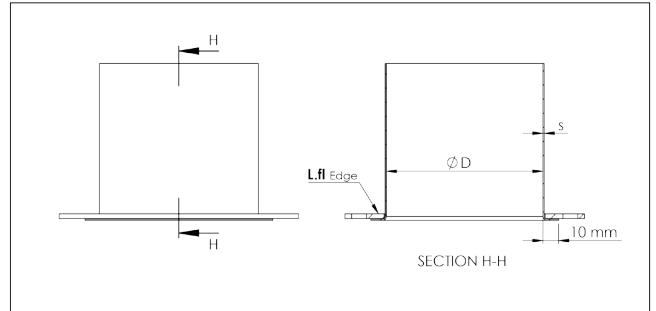

**L.ct2fl, L.ct3fl, L.ct4fl edge :**

A "L.ctxfl" edge is a 10 mm edge on standard ducting with a loose DIN REIHE Stainless Steel flange mounted on the component. (AISI 304)

The edge can be slightly rounded or perfectly square at the fold depending on the folding method although a square execution is preferable.

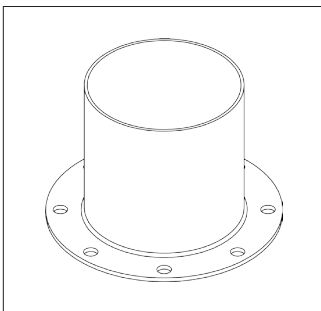
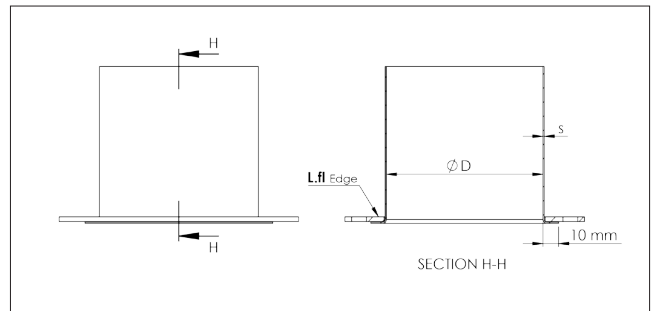

**W.t2fl, W.t3fl, W.t4fl edge :**

A "W.txfl" edge is a component with a fully welded DIN REIHE flange along the edge.

The edge can be slightly rounded or perfectly square at the fold depending on the folding method although a square execution is preferable.

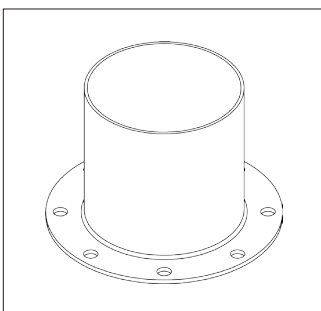
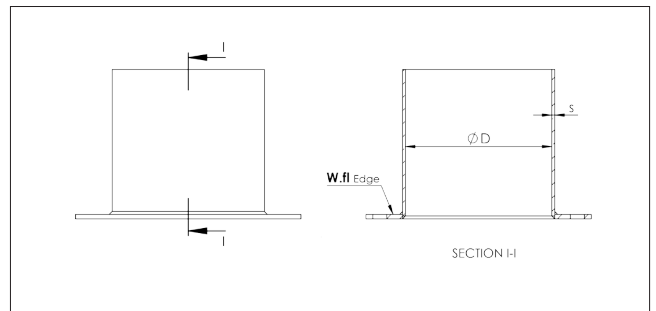

**W.ct2fl, W.ct3fl, W.ct4fl edge :**

A "W.ctxfl" edge is a component with a fully welded DIN REIHE flange along the edge. (AISI 304)

The edge can be slightly rounded or perfectly square at the fold depending on the folding method although a square execution is preferable.

