

AADC Sliding dampers with seal

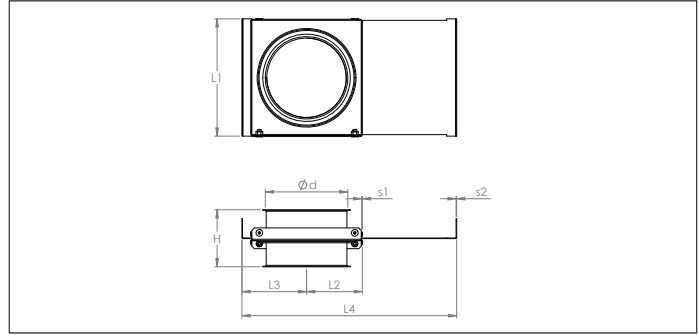

AADC Sliding dampers with seal

Robust manual sliding dampers with rubber and PEHD polyether sealing ring for use in under-pressure and pressureless systems.

The airtightness is achieved up to Ø 200 mm with two gaskets sets (EPDM and PEHD) but with only one plastic gasket set as of Ø 225 mm. The plastic seal can be replaced by Teflon depending on the temperature.

Only applied when a ducting needs to be completely open or closed.

Material

Electro-galvanized blacksteel (10µm) with EPDM and PEHD seals.

Type

Rolled, folded and welded sheets with 6 mm edges for lock rings.

Options

- other diameters
- Teflon seals
- other sheet thicknesses depending on diameter
- other types of edges or connections

Ø	Code	L1 mm	L2 mm	L3 mm	L4 mm	H mm	S1 mm	S2 mm	Weight kg
80	AADC000001	150	73	92	274	125	1.50	2.00	1.80
100	AADC000002	177	83	102	314	125	1.50	2.00	2.25
120	AADC000003	202	97	114	359	125	1.50	2.00	2.80
125	AADC000021	202	97	114	359	125	1.50	2.00	2.80
140	AADC000004	227	108	127	414	125	1.50	2.00	3.40
150	AADC000005	227	108	127	414	125	1.50	2.00	3.40
160	AADC000006	237	113	132	434	125	1.50	2.00	3.60
180	AADC000007	277	133	152	514	125	1.50	2.00	4.70
200	AADC000008	277	133	152	514	125	1.50	2.00	4.50
225	AADC000009	335	136	154	544	163	2.00	3.00	7.80
250	AADC000010	370	148	167	594	163	2.00	3.00	8.90
275	AADC000011	420	183	202	714	163	2.00	3.00	11.00
280	AADC000022	420	183	202	714	163	2.00	3.00	11.00
300	AADC000012	420	183	202	714	163	2.00	3.00	11.50
315	AADC000013	470	208	226	813	163	2.00	3.00	11.50
350	AADC000014	470	208	226	813	163	2.00	3.00	13.70
400	AADC000015	520	233	252	913	163	2.00	3.00	16.50
450	AADC000016	568	257	276	1009	221	2.00	3.00	19.70
500	AADC000017	618	282	301	1109	221	2.00	3.00	22.60
550	AADC000018	750	348	367	1373	221	2.00	3.00	35.00
600	AADC000019	750	348	367	1373	221	2.00	3.00	34.00
630	AADC000020	750	348	367	1373	221	2.00	3.00	33.00