



Throttle valves
Manual, Pneumatic & Electric

Maintenance Manual

Contents

1. <i>PRODUCT DESCRIPTION</i>	2
1.1. <i>How it works</i>	2
1.2. <i>Throttle valve types</i>	2
1.2.1. <i>Manual throttle valves</i>	3
1.2.2. <i>Pneumatic throttle valves</i>	3
1.2.3. <i>Electrical throttle valves</i>	3
2. <i>INTALLATION</i>	4
2.1. <i>Throttle valve installation</i>	4
3. <i>MAINTENANCE & TROUBLESHOOTING</i>	6
3.1. <i>Maintenance</i>	6
3.1.1. <i>Electric motor and actuator maintenance</i>	6
3.1.2. <i>Pneumatic actuator maintenance</i>	6
3.2. <i>Troubleshooting</i>	7
3.2.1 <i>Replacing the throttle valve gasket (models with gasket)</i>	7
3.2.2 <i>Replacing the throttle valve blade</i>	7
3.2.3. <i>Replacing the handle of manual throttle valves</i>	8
3.2.4. <i>Replacing the pneumatic actuator for pneumatic throttle valves</i>	9
3.2.5. <i>Replacing the electrical actuator for electric throttle valves</i>	9
3.2.5. <i>Replacing the electric motor for electric throttle valves</i>	10
3.2.6. <i>Replacing the driven axle (common for all the throttle valves types)</i>	11
3.2.7. <i>Replacing the driving axle (different depending on throttle valve model)</i>	12
4. <i>DISMANTLING & RECYCLING</i>	13
5. <i>SPARE PARTS</i>	14

Throttle valves. Maintenance Manual

1. PRODUCT DESCRIPTION

The throttle valves are used for airflow regulation as well as for isolation. The throttle valves are manufactured in Sendzimir galvanized steel. To improve the airtightness, the throttle valves can be equipped with a gasket.

1.1. How it works

The throttle valves are designed to control the airflow through an installation controlled by a handle, by an electric actuator or motor, or by a pneumatic actuator. When the valve is closed, the blade is turned so that it completely blocks the airflow through the ducting. The following illustration shows the airflow running through the throttle valve.

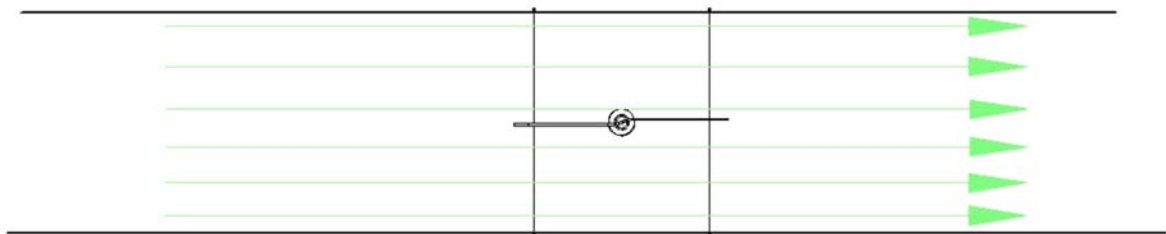

VALVE OPENED. FREE AIR FLOW

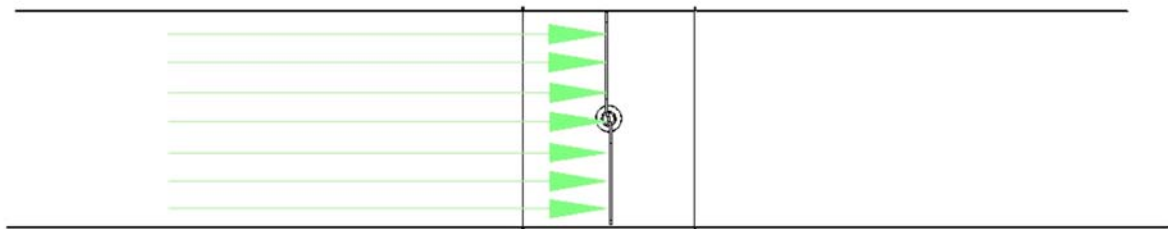

VALVE CLOSED. NO AIR FLOW

1.2. Throttle valve types

The standard throttle valves are available in the following types:

- Manual throttle valves
- Pneumatic throttle valves
- Electric throttle valves

1.2.1. Manual throttle valves

A handle allows to position the blade and it can be set in different positions from opened to closed. Valve position is shown by the handle.

Available without or with gasket.

* For overall dimensions, please see attached tables in **Chapter 1.3**.



1.2.2. Pneumatic throttle valves

The throttle valve is controlled by a pneumatic rotating actuator.

Available without or with gasket.

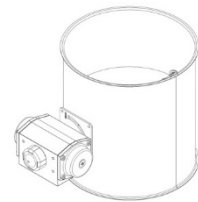

Technical data for pneumatic actuator

Pressure max. (bar)	String type	Air consumption for stroke (l)		Operating temperature (°C)
		Min	max	
10	Double acting	0.09	0.20	From -5 to +80

* For overall dimensions, please refer to the technical datasheets.

1.2.3. Electrical throttle valves

The throttle valve is controlled by an electric actuator or electric motor.

Available without or with gasket.

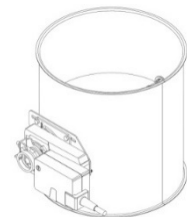

Technical data for electric actuator

Range of product	Nominal Torque (Nm)	Nominal Voltage	Power consumption		Control	Direction of rotation
			24 V	220 V		
From Ø80 to Ø160	5	AC/DC 24... 240 V, 50/60 Hz	1.5 W	3 VA	Open-close	Reversible
From Ø180 to Ø800	20	AC/DC 24... 240 V, 50/60 Hz	2.5 W	6 VA	Open-close	Reversible

* For overall dimensions, please refer to the technical datasheets.

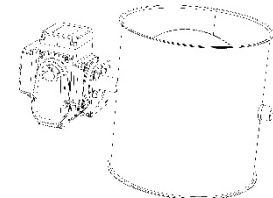

Technical data for electric motor

Range of product	Nominal Torque (Nm)	Nominal Voltage	Power consumption		Control	Direction of rotation
			24 V	220 V		
From Ø80 to Ø800	50	AC/DC 24... 240 V, 50/60 Hz	20 W	10 W	Open-close	Reversible

* For overall dimensions, please refer to the technical datasheets.

2. INTALLATION



The installation, start-up and maintenance of the throttle valve has to be performed by qualified personnel only. For heavy parts use the right equipment and do not work alone.

2.1. Throttle valve installation

Step 1: Fix the throttle valve to the ducting, using suitable rings. Seals can be added to the rings for improved airtightness.

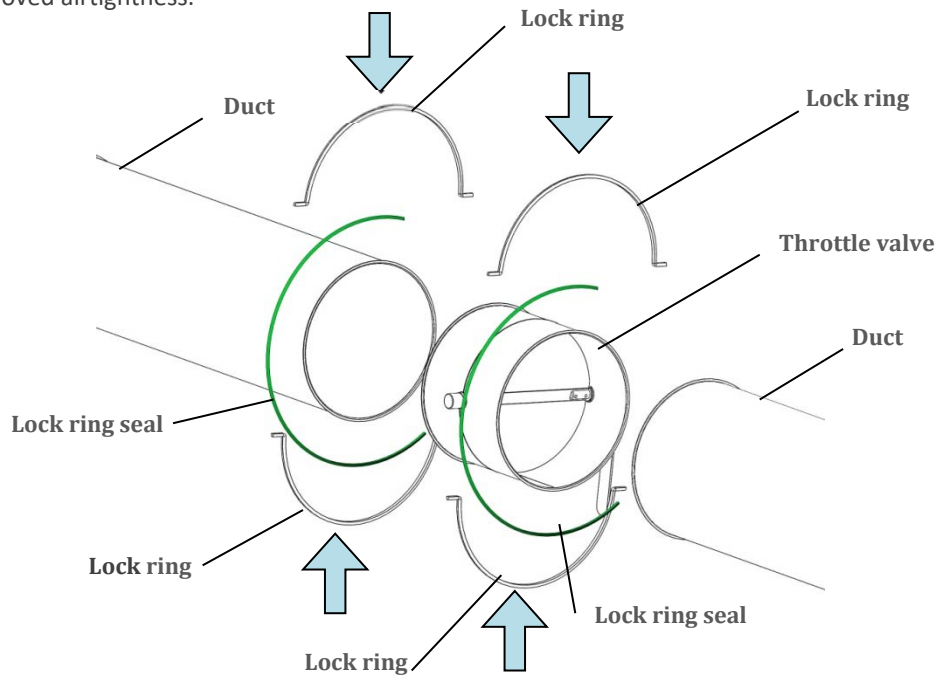

Step 2: Position the valve.

- *Manual throttle valves*

Position the throttle valve blade with the handle's help.

Loosen the wing nut without totally unscrewing the bolt and rotate the handle to the desiderated position. Tighten the wing nut to maintain de throttle valve blade in the desired position.

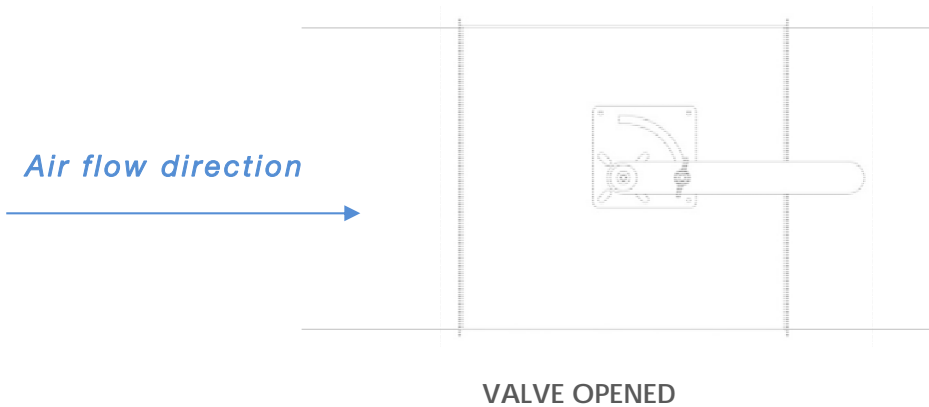

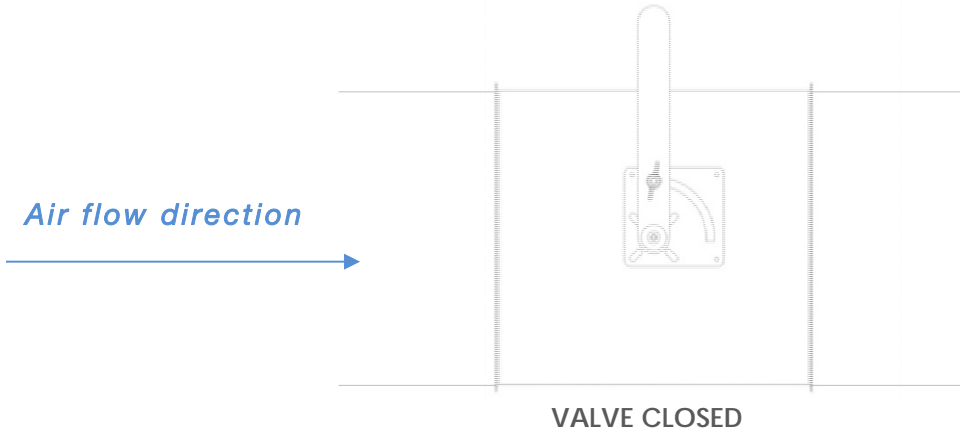

Step 3: for pneumatic and electric versions, make the necessary connections.

- Electrical throttle valves with electric actuator

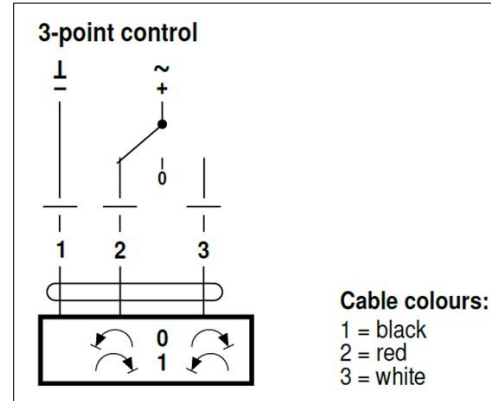
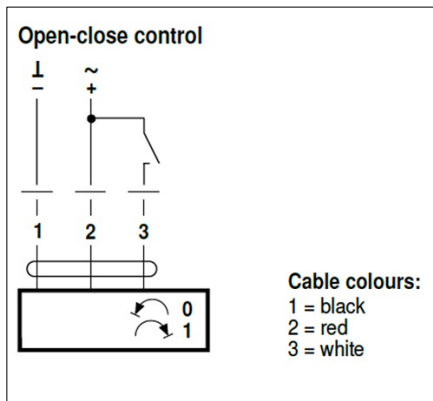

CAUTION! The actuator may only be opened and repaired by the manufacturer. It does not contain any parts that can be replaced by the user. Any modifications will annul the warranty.

CAUTION! The cable must not be removed from the actuator.

- Electrical throttle valves with electric motor

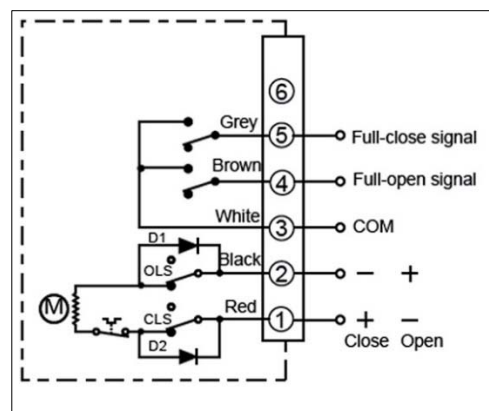
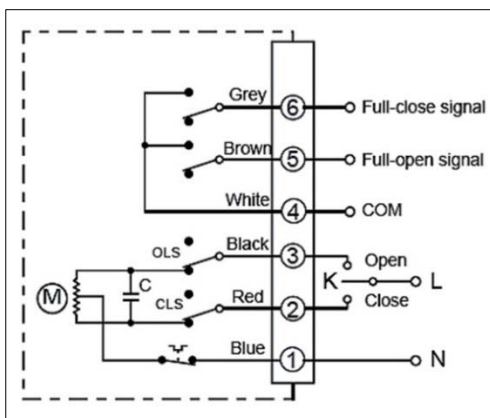

CAUTION! The motor may only be opened and repaired by the manufacturer. It does not contain any parts that can be replaced by the user. Any modifications will annul the warranty.

- Pneumatic throttle valves

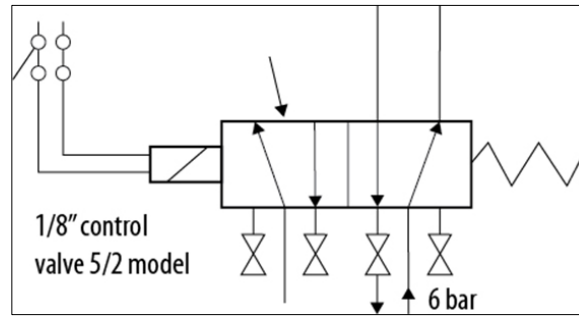

Use only filtered dry oil free air for the pneumatic rotating actuator.



CAUTION! The actuator may only be opened and repaired by the manufacturer. It does not contain any parts that can be replaced by the user. Any modifications will annul the warranty.

3. MAINTENANCE & TROUBLESHOOTING



The installation, start-up and maintenance of the throttle valve has to be performed by qualified personnel only. For heavy parts use the right equipment and do not work alone.

3.1. Maintenance



During the maintenance keep the system disconnected and all the electrical equipment turned off.

Clean and check the performance of the throttle valves regularly.

3.1.1. Electric motor and actuator maintenance

The electric motors and actuators are maintenance free. When fully depressurized the actuators can be operated by hand levers or gearboxes for emergency operation. The actuators can be mounted in any position. Before mounting the actuators on the valve, make sure that the actuators shaft and the valve shaft are aligned properly to avoid any friction. When dismantling make sure that the air supply and all electrical connections have been disconnected.

3.1.2. Pneumatic actuator maintenance

Moving parts are factory lubricated for cycle life. Use filtered dry oil free air. When fully depressurized the actuators can be operated by hand levers or gearboxes for emergency operation. The actuators can be mounted in any position. Before mounting the actuators on the valve, make sure that the actuators shaft and the valve shaft are aligned properly to avoid any friction. When dismantling make sure that the air supply and all electrical connections have been disconnected.



3.2. Troubleshooting

During the valve's manipulation keep the system disconnected and all the electrical equipment turned off.

3.2.1 Replacing the throttle valve gasket (models with gasket)

we recommend replacing the whole throttle valve blade with integrated gasket.

Please refer to the point 3.2.2 Replacing the throttle valve blade for further instructions.

3.2.2 Replacing the throttle valve blade

Step 1: remove the screws from the axles that hold the blade.

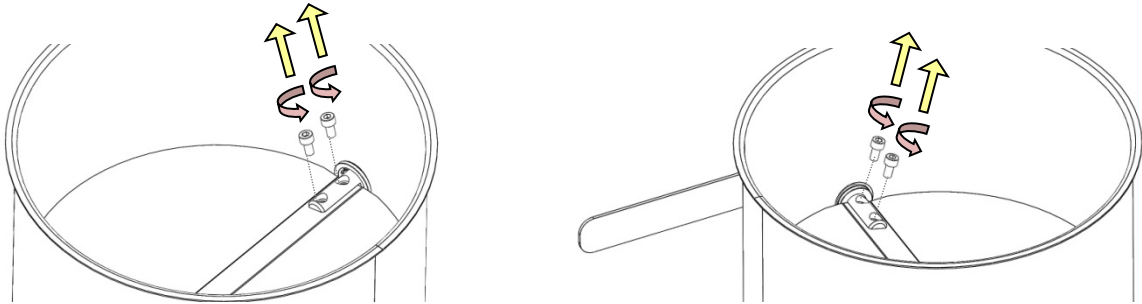

Step 2: Take the blade out. Rotate the blade to the open position and slide it through the axles.

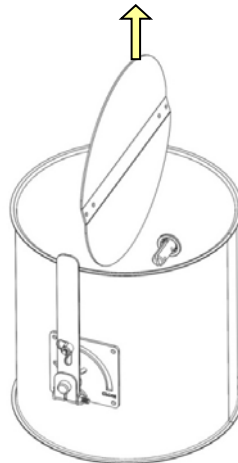

Step 3: Replace the damaged blade with a new one by sliding it through the axles.

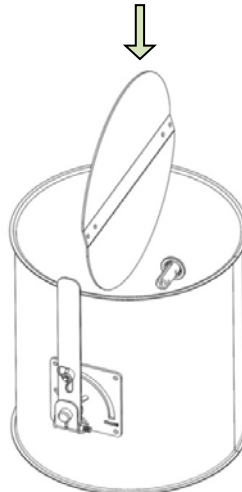

Step 4: secure the new blade by screwing it to the axles.

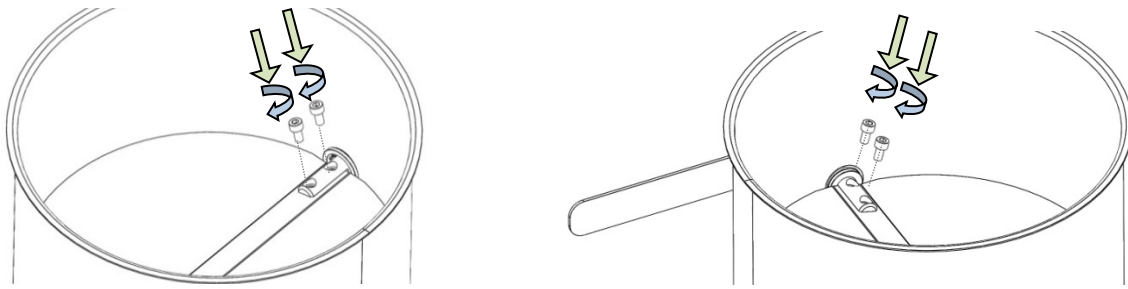

3.2.3. Replacing the handle of manual throttle valves

Step 1: Unscrew the wing nut from the handle.

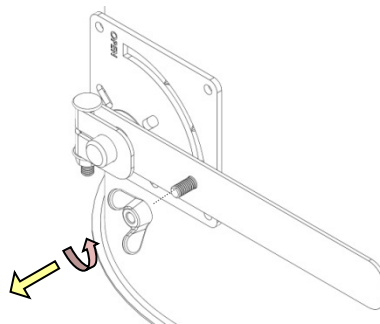

Step 2: Unscrew the bolt and the nut which press the handle. Take the handle off.

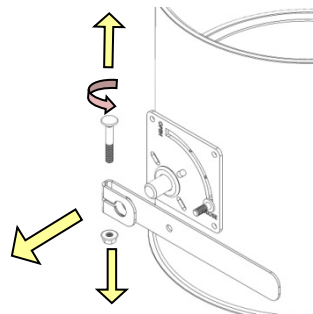

Step 3: Replace the handle.

Step 4: Insert the handle into the axle. Tighten it with the bolt and nut.

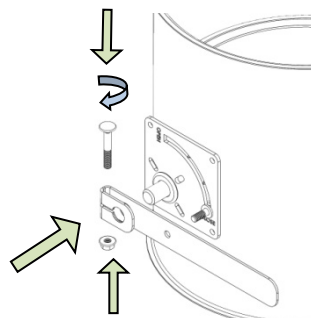

IMPORTANT!

Make sure the handle is in the right position compared to the blade before tightening the bolt and nut.

Step 5: Rotate the handle to the desiderate position and tighten the wing nut.

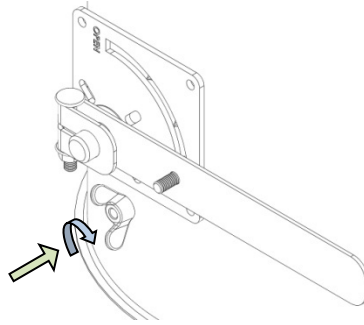

3.2.4. Replacing the pneumatic actuator for pneumatic throttle valves

Step 1: Take the pneumatic actuator off by unscrewing nuts on the back of the support plate.

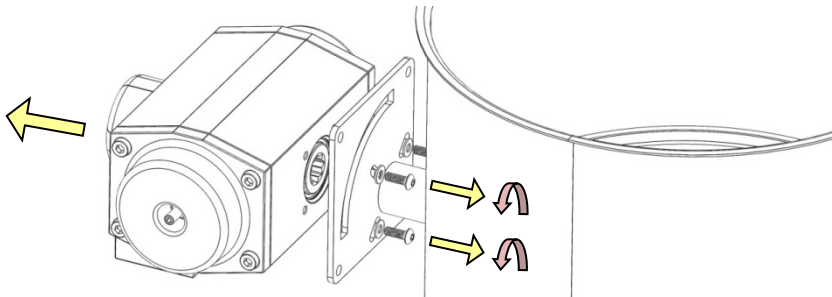

Step 2: Remove the pneumatic actuator and replace it with the new one.

Step 3: Place the pneumatic actuator onto the plate and attach it with the nuts.

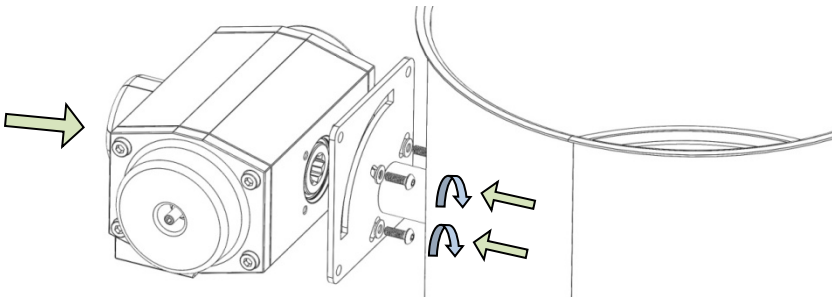

Step 4: make the necessary electric and pneumatic connections.

3.2.5. Replacing the electrical actuator for electric throttle valves

Step 1: Loosen the electrical actuator by unscrewing the nuts of the U-bolt.

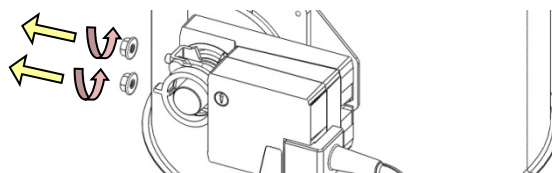

Step 2: Tilt the electrical actuator backwards and remove it.

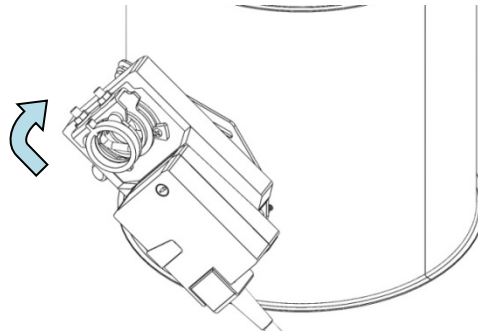

Step 3: Replace the actuator.

Step 4: Place the electrical actuator back by hooking it behind the positioning screw.

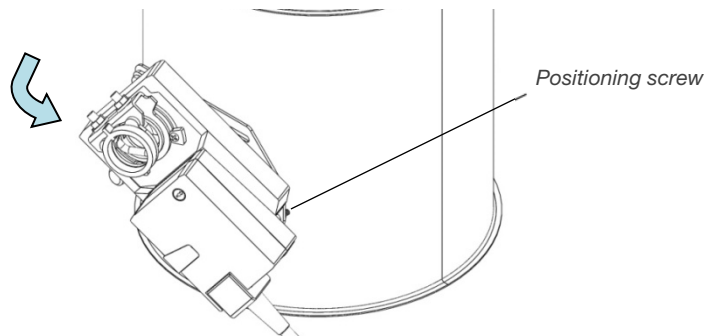

Step 5: Tight the actuator to the axle by screwing the nuts on the U-bolt.

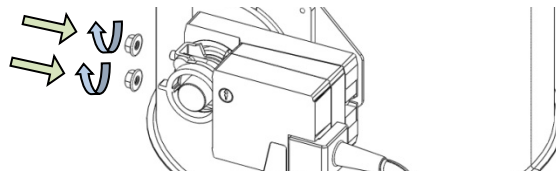

3.2.5. Replacing the electric motor for electric throttle valves



CAUTION! Make sure all electrical connections are disconnected before starting the maintenance.

Step 1: Loosen the electric motor by unscrewing the nuts on the back of the support plate.

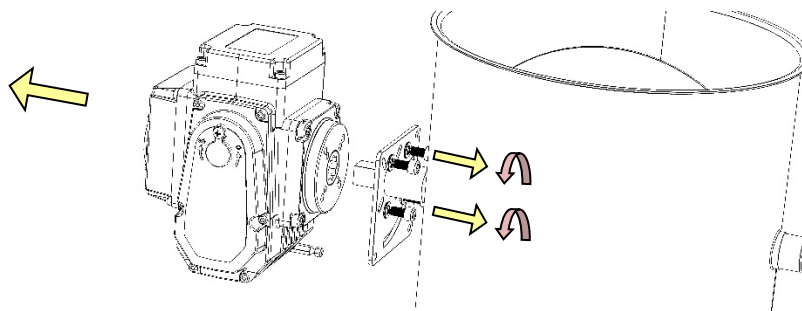

Step 2: Remove the pneumatic actuator and replace it with the new one.

Step 3: Place the pneumatic actuator onto the plate and attach it with the nuts.

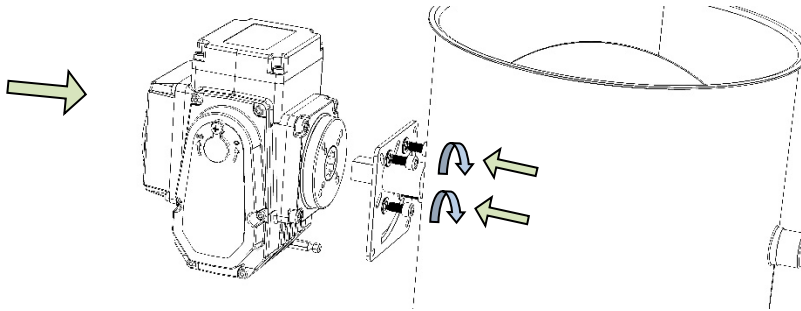

Step 4: make the necessary electric connections.

3.2.6. Replacing the driven axle (common for all the throttle valves types)

Step 1: Take the blade out of the throttle valve. Follow the *Step 1* to *Step 2* in *Chapter 3.2.2*.

Step 2: Slide the short axle out of its support.

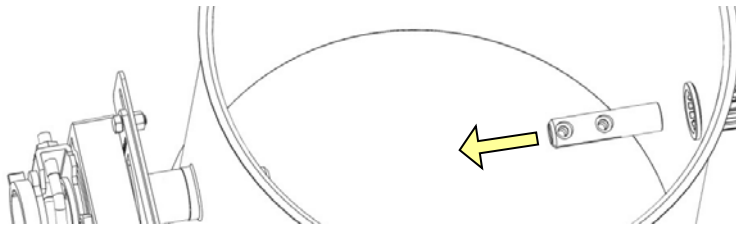

Step 3: Insert the new driven axle in its support.

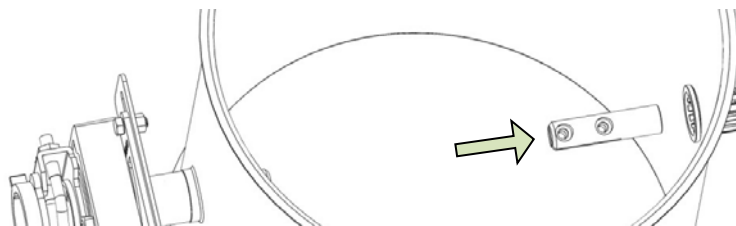

Step 4: Attach the blade as described in the *Step 3* to *Step 4* in *Chapter 3.2.2*.

3.2.7. Replacing the driving axle (different depending on throttle valve model)

Step 1: Take the handle out. Follow the *Step 1 to Step 2* in *Chapter 3.2.3*.

Step 2: Slide the axle through the axle support.

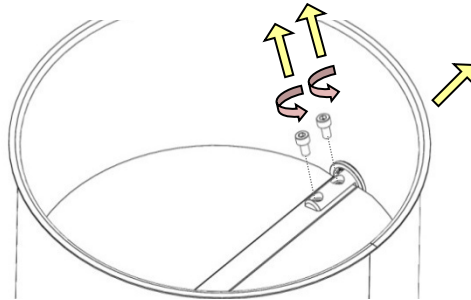

Step 3: Insert the new axle through the axle support duct's hole and screw it to the flap.

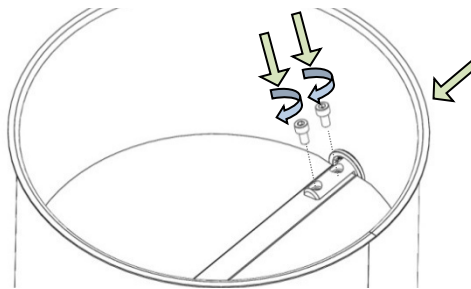

Step 4: Attach the blade as described in the *Step 3 to Step 4* in *Chapter 3.2.2*.

4. DISMANTLING & RECYCLING

When dismantling a unit, be sure to keep in mind the following important information:

As the unit is dismantled, set aside all still functioning parts in order to re-use them on another unit.

You should always separate the different materials depending on their type : iron, rubber, oils, greases, etc...

Recyclable parts must be disposed of in the appropriate containers or brought to a local recycling company.

The rubbish must be collected in special containers with appropriate labels and disposed of in compliance with the national laws and/or local legislations in force.

CAUTION! It is strictly forbidden to dispose of toxic wastes in municipal sewerage and drain systems. This concerns all oils, greases, and other toxic materials in liquid or solid form.



5. SPARE PARTS

For spare parts please contact the Formula Air Group.

Formula Air France Nord

Zac de la Carriere Dorée
BP 105,
59310 Orchies, France
Tel : +33 (0) 320 61 20 40
contact-nord@formula-air.com

Formula Air Nordic

Södra Vallviksvägen 12
352 57 Vaxjö,
Sweden
Tel : +46 (0)8 12 41 01 24
info-scan@formula-air.com

Formula Air Belgium

Rue des Dizeaux 4
1360 Perwez,
Belgium
Tel: +32 (0) 81 23 45 71
info-be@formula-air.com

Formula Air France Est

2, rue Armand Bloch
25200 Montbéliard,
France
Tel : +33 (0) 381 91 70 71
contact-est@formula-air.com

Formula Air Russia

Нижний Новгород
Россия
Tel : +7920008 88 75
info-ru@formula-air.com

Formula Air Germany

Dr. Oetkerstrasse 10
54516 Wittlich,
Germany
Tel 49 (0) 65 71 26 98 6-0 info-de@formula-air.com

Formula Air France Sud

Chemin de Peyrecave
09600 Regat,
France
Tel : +33 561 66 79 70
contact-sud@formula-air.com

Formula Air The Netherlands

Boscheweg 36
5741 SX Beek en Donk,
The Netherlands
Tel : +31 (0) 45 492 15 45
info-nl@formula-air.com

Formula Air Baltic

P. Motiekaicio g. 3
77104, Šiauliai,
Lithuania
Tel: +370 41 54 04 82
info-lt@formula-air.com

Formula Air France Ouest

6 Avenue des Lions
44800 Saint Herblain,
France
Tel : +33 (0) 251 89 90 75
contact-ouest@formula-air.com

Formula Air Export

Rue des Dizeaux 4
1360 Perwez,
Belgium
Tel : +32 (0) 81 23 45 71
customerservice@formula-air.com

www.formula-air.com

NOTE : All drawings and references contained within this manual are non-contractual and are subject to change without prior notice at the discretion of the Formula Air group and its partners.